



Pure View[®] Full Glass Panel

TABLE OF CONTENTS

English

Introduction.....	3
Level Bracket.....	4
Angled Bracket.....	27
Care & Maintenance/Warranty.....	35

INTRODUCTION

READ INSTRUCTIONS COMPLETELY BEFORE STARTING INSTALLATION

It is the responsibility of the installer to meet all code and safety requirements, and to obtain all required building permits. The deck and railing installer should determine and implement appropriate installation techniques for each installation situation. Fortress Railing Products and its distributors shall not be held liable for improper or unsafe installations.

Fortress Posts must always be secured to the deck framing and should never be attached to only the deck boards.

Pure View I-Support is required for Canadian Code Compliance.

Note

When cutting Fortress railing, it is very important to complete the following at cut points:

- Remove all metal shavings from the cut area.
- File any sharp edges left by cutting. Thoroughly wipe and remove any filings, grime, or dirt from the railing.
- Apply two coats of Fortress zinc based touch-up paint to the cut area. If touch up is at rail ends, allow paint to dry before connecting bracket to post.
- Be sure to remove any metal shavings from the surface of deck, patio, or balcony to prevent stains on the deck surface.

Torx Safety Tips

- Always use the lowest speed setting on drill.
- To reduce chance of bit breakage, start tightening with drill on low torque setting and work up until screw is secured.

Tip: Pre-drill holes with 3/16" [5mm] drill bit.

Required Tools



Pure View: Al¹³ HOME Full Glass Panel Installation Options

2" [51mm] or 3" [76mm] Proud Post

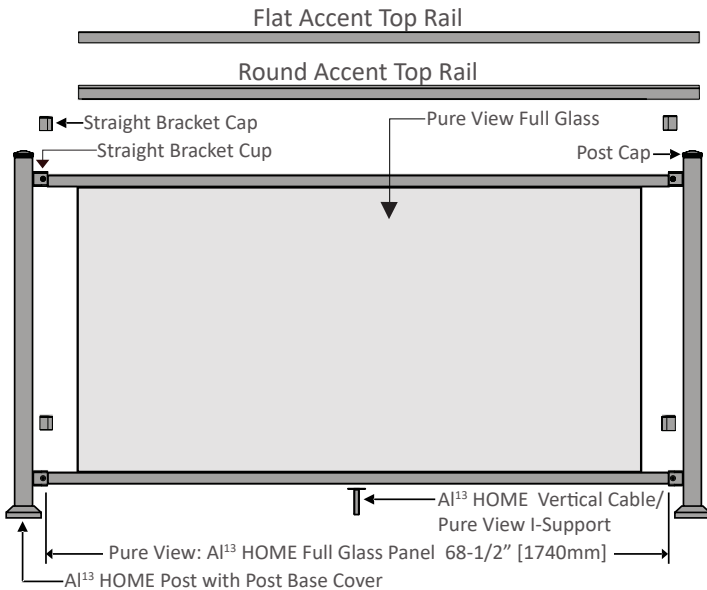

2" [51mm] or 3" [76mm] Proud Post Configurations

AI¹³ HOME Panel Height

32-1/2" [826mm]

40" [1016mm]

Rail Panel

Installed Panel Height

36" [914mm]

42" [1067mm]

Required Post

39-1/2" [1003mm]

45-1/2" [1156mm]

*Installed heights include a 3-1/2" [89mm] for the 32-1/2" [826mm] panel & 2" [51mm] for the 40" [1016mm] panel space between deck surface and bottom edge of bottom rail.

2" [51mm] Over The Post (OTP)

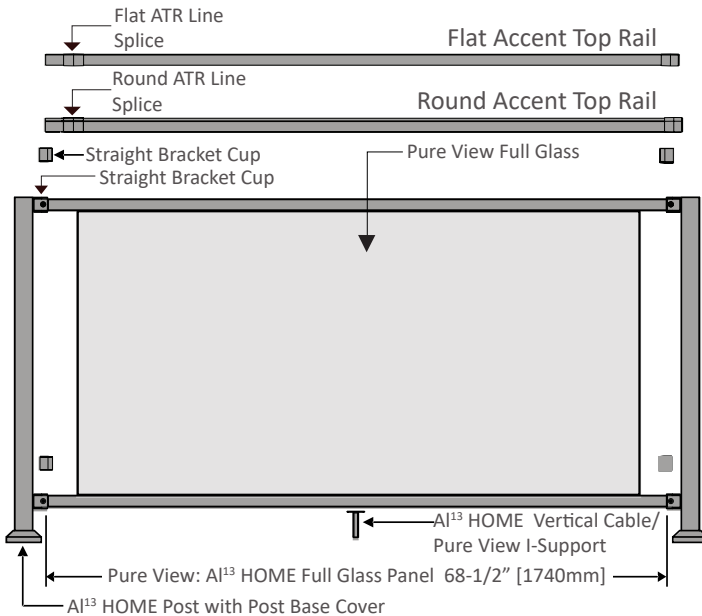

2" [51mm] Over The Post (OTP) Configurations

AI¹³ HOME Panel Height

32-1/2" [826mm]

40" [1016mm]

Rail Panel

Installed Panel Height

36" [914mm]

42" [1067mm]

Required Post

36" [914mm]

42" [1067mm]

*Installed heights include a 3-1/2" [89mm] for the 32-1/2" [825.5mm] panel & 2" [51mm] for the 40" [1016mm] panel space between deck surface and bottom edge of bottom rail.

Full Glass Panel Size Chart

32 1/2" [825.5mm] & 40" [1016mm] Panels

Glass Widths	3" [76mm] Post O.C. Spacing	2" [51mm] Post O.C. Spacing	Between Post Spacing
12.25" [838mm x 311mm]	18" to 23" [457mm to 584mm]	17" to 22" [432mm to 559mm]	15" to 20" [381mm x 508mm]
18.25" [838mm x 464mm]	24" to 29" [610mm to 584mm]	23" to 28" [584mm to 711mm]	21" to 26" [533mm x 660mm]
24.25" [838mm x 616mm]	30" to 35" [762mm to 889mm]	29" to 34" [736.5mm to 863.5mm]	27" to 32" [686mm x 813mm]
31.25" [838mm x 794mm]	37" to 42" [940mm to 1067mm]	36" to 41" [914.5mm to 1041.5mm]	34" to 39" [868mm x 991mm]
36.25" [838mm x 921mm]	42" to 47" [1067mm to 1194mm]	41" to 46" [1041.5mm to 1168.5mm]	39" to 44" [991mm x 1118mm]
41.25" [838mm x 1048mm]	47" to 52" [1194mm to 1321mm]	46" to 51" [1168.5mm to 1295.5mm]	44" to 49" [1118mm x 1245mm]
46.25" [838mm x 1175mm]	52" to 57" [1321mm to 1448mm]	51" to 56" [1295.4mm to 1422.4mm]	49" to 54" [1245mm x 1372mm]
51.25" [838mm x 1302mm]	57" to 62" [1448mm to 1575mm]	56" to 61" [1422.4mm to 1549.4mm]	54" to 59" [1372mm x 1499mm]
56.25" [838mm x 1429mm]	62" to 67" [1575mm to 1702mm]	61" to 66" [1549.4mm to 1676.4mm]	59" to 64" [1499mm x 1626mm]
61.25" [838mm x 1556mm]	67" to 72" [1702mm to 1829mm]	66" to 71" [1676.4mm to 1803.4mm]	64" to 69" [1626mm x 1753mm]

Note:

32 1/2" [825.5mm] panel uses a 31-1/2" [800mm] tall piece of glass and a 40" [1016mm] panel uses a 39" [990.5mm] tall piece of glass.

POST MOUNTING

*If using Fortress Evolution Framing, contact Fortress for instructions.

Note:

It's recommended to install brackets into post before post mounting. Reference page 9 for Bracket installation steps.

Step 1: Install Wood Blocks

1. Install Wood Block level with top of joist. As shown in Fig. 1.

2. Secure Wood Block to blocking on all four sides with #10 X 3-1/2" [89mm] deck screws.
 - Wood Block must be constructed with treated dimensional lumber with a minimum thickness of 1-1/2" [38mm].

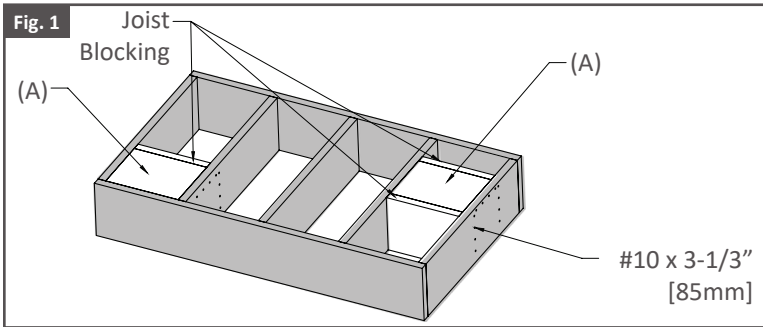

Step 2: Position Base Plate

1. Position the edge of base plate a minimum of 1/2" [13mm] from the inside edge of rim joist. As shown in Fig. 2.

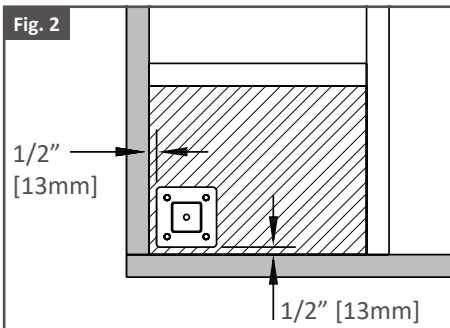

Step 3: Max Post Spacing

- 68-1/2" [1740mm] AL13 HOME Rails maximum post spacing is 68-3/4" [1746mm].

Note:

- **DO NOT** exceed the maximum post spacing.

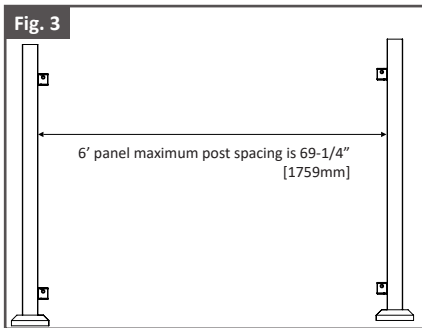

Step 4: Mount Posts

1. Mark mounting hole locations and pre-drill a 3/8" [10mm] hole.
2. Insert 3/8" x 3-1/2" [10mm x 89mm] Hex Head galvanized bolts through 3/8" [10mm] galvanized washer and post base plate.

Note:

- Post Base Plate holes **MUST** be positioned a minimum 1/2" [13mm] from edge of deck board.
- Use only 3/8" [10mm] Hex Head Galvanized Bolts. Lag Screws should **NOT** be used. Secure each post with four bolts.

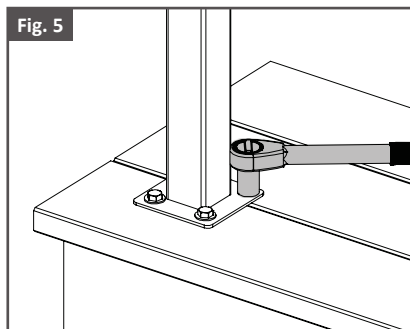
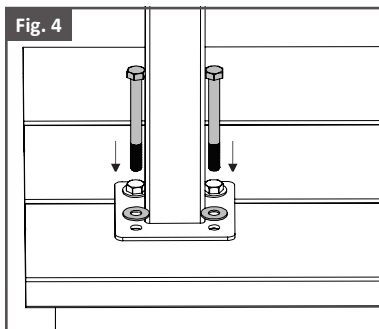

Step 5: Check Mounted Posts

1. Shim post as needed to ensure post is level.

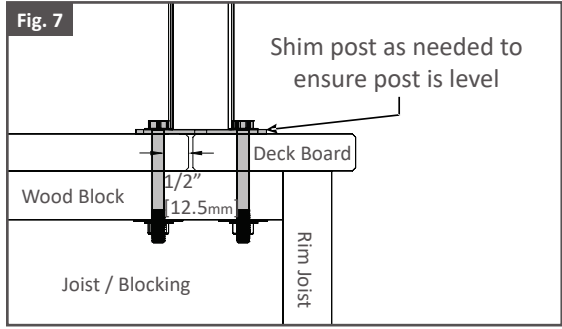
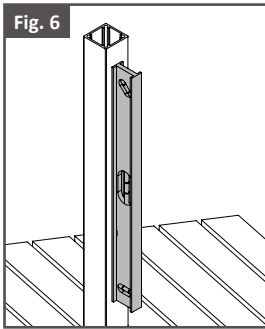

BRACKET INSTALLATION

Step 1: Mark Bracket Hole Locations

1. Mark the centerline of each post with a pencil.
2. Take measurements used in Fig. 8 and 9 to mark bottom and top bracket hole locations onto posts.

Fig. 8 **Bracket Hole Locations**

Pre-drill Dimensions: Pre-drilling with a 3/16" [5mm] drill bit is required

A*	B	C	D
(1) 32-1/2" [825.5mm] Panel			
4" [101.5mm]	3/8" [10mm]	35-3/16" [894mm]	11/16" [17mm]
(2) 40" [1016mm] Panel			
2-1/2" [63.5mm]	3/8" [10mm]	41 1/4" [1048mm]	11/16" [17mm]

*Dimension A positions bottom edge of rail (1) 3-1/2" [89mm] and (2) 2" [51mm] above deck surface.
 *Dimension A is measured from the bottom surface of post base.

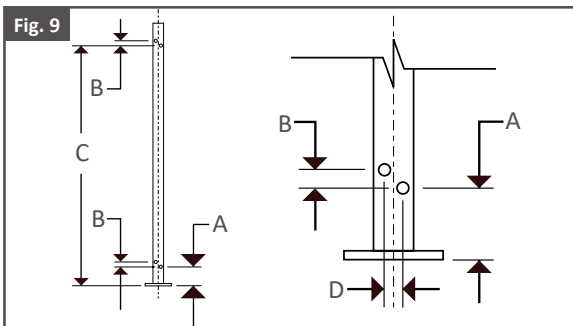

Step 2: Pre-Drill and Install Brackets

Tip:

- **It's important to double check dimensions to confirm accuracy of bracket hole locations before drilling.**
1. Use Spring Punch to mark the holes. As shown in Fig. 10.
 2. Pre-drill bracket holes with a 3/16" [5mm] drill bit. As shown in Fig. 11.
 3. Attach Bracket to the posts with supplied T-25 Thread-Cutting Screws. Use two screws per bracket. Use low speed setting on drill. As shown in Fig. 12.
 4. Once top and bottom brackets are installed, remeasure bracket spacing to confirm dimensions used in Fig. 8 and 9 of step 1. As shown in Fig. 13.
 5. Remove all metal shavings from deck, post base cover, post, and panel before bracket is screwed to post to prevent corrosion.

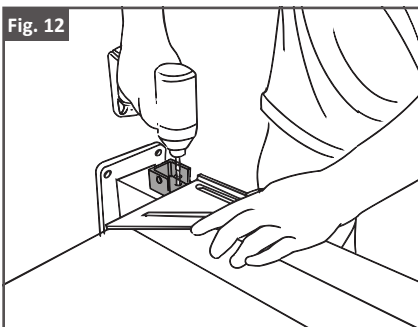
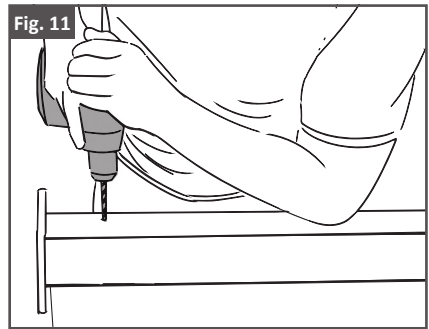
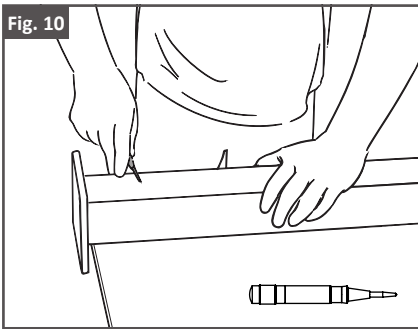
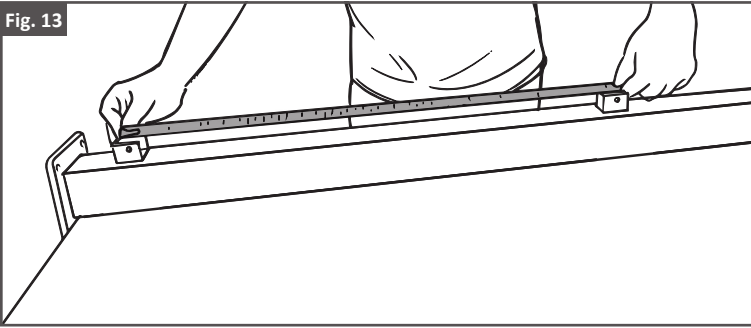

Fig. 13



Step 3: Measure The Panel Opening Length

1. Measure the distance of the panel opening. As shown in Fig. 14.
2. Confirm that the measurements for the top brackets are the same as the bottom brackets.

Note:

- **Measure from the back wall of the bracket to the back wall of the bracket on other post. As shown in Fig. 15.**

Fig. 14

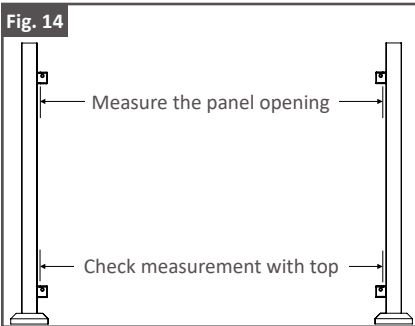
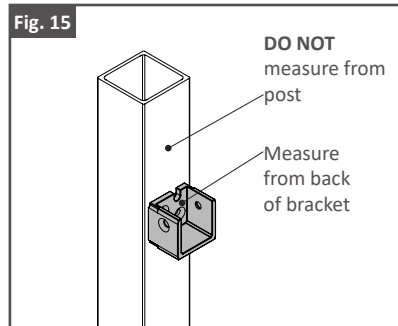

Fig. 15



CUTTING DOWN BOTTOM AND TOP RAILS

Step 1: Measure & Mark Rails Where Cuts Will Be Made

1. Take measurements found on page 11, step 3 of Bracket Installation and mark these locations with a pencil on the top and bottom rail.

Tip:

- Before cutting rails, confirm Full Glass Panel spacing. The space between glass and post should not exceed 4" [102mm] on each side. As shown in Fig. 16.
- Total panel opening length should be glass width plus 8" [203mm] max.

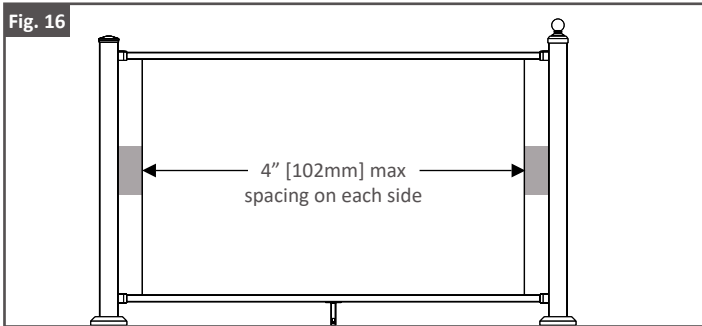

Step 2: Cut & Clean Rails

1. Cut rails using a saw with a fine tooth carbide cutting blade.
2. Use file to smooth cut edges.
3. Remove any metal shavings and dust with a brush or rag.
4. Make sure surfaces to be painted are clean.

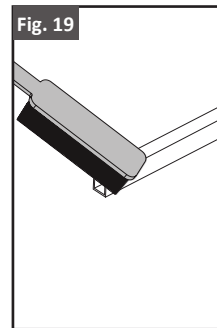
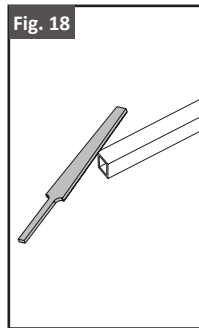
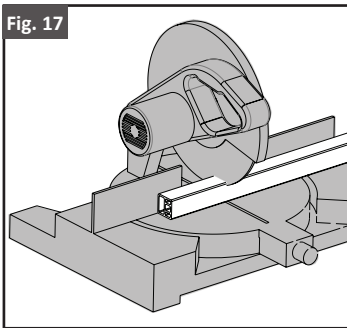

Step 3: Apply Spray Paint To Cut Areas

1. Using a piece of cardboard as a mask, apply the 1st coat of Fortress zinc based touch-up paint.
2. Allow to dry before applying second coat.
3. Apply the 2nd coat of Fortress zinc based touch-up paint.
4. Allow to dry and install.

Fig. 20

2X

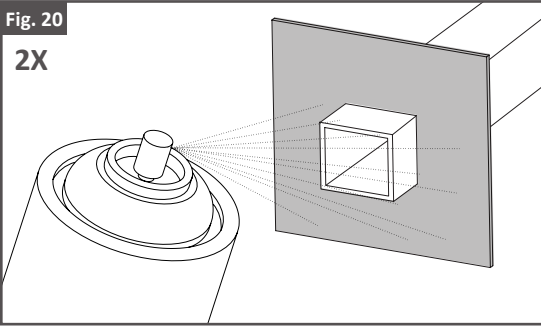

FULL GLASS PANEL INSTALLATION

Step 1: Install I-Support On Bottom Rail

1. Measure and locate the center of the bottom rail. Using the I-Support as a guide, mark the center of the 2 screw holes. As shown in Fig. 21.
2. Using a 3/16" [5mm] drill bit, drill through the outside wall.
3. Install the I-Support with the provided Phillips Head thread cutting screws. As shown in Fig. 22.

Note:

- Be sure to install I-Support on side of rail facing deck.

Fig. 21

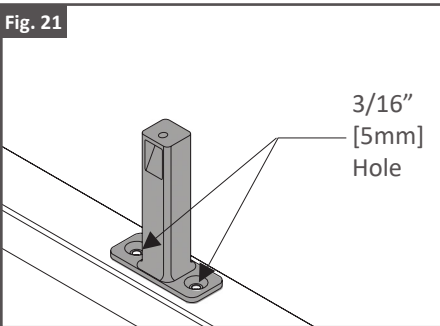
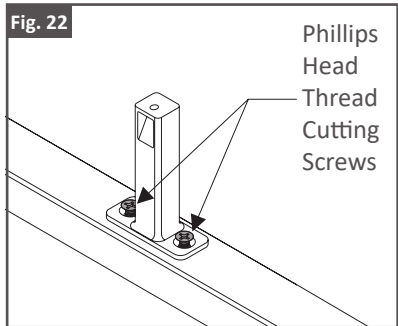

Fig. 22



Step 2: Install Bottom Rail

1. Install cut bottom rail into the lower installed brackets.
2. Pre-drill Bracket Cup holes for screws using a 3/16" [5mm] drill bit.
3. Secure rail to Bracket Cups with provided T-25 Drive Thread-Cutting Screws. Use low speed setting on drill.

Tip:

- It is recommended to apply a small amount of liquid soap to the black gasket openings in the top and bottom rails before installing Full Glass. As shown in Fig. 25. The Liquid Soap helps the glass settle in place.

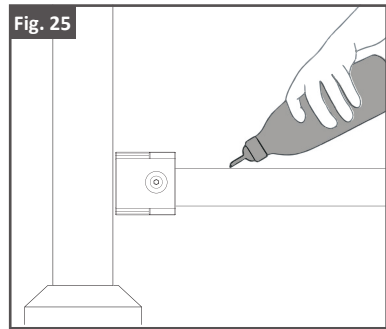
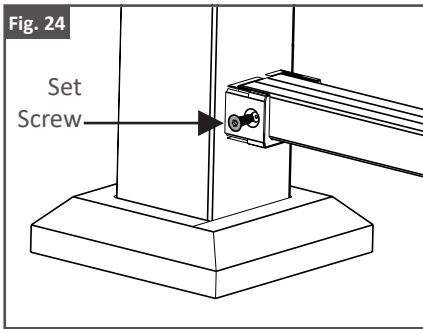
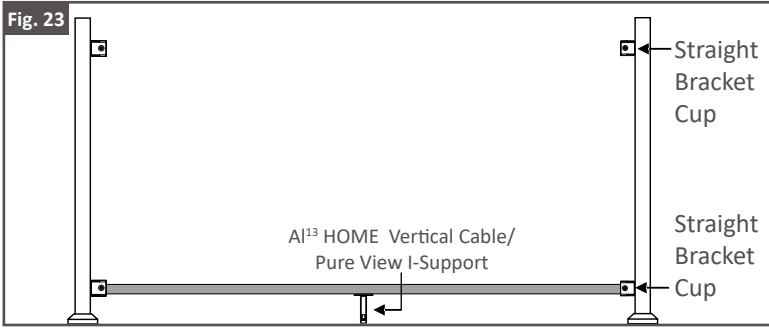

Step 3: Install Full Glass Into Bottom Rail

1. Carefully position full glass sheet into the center of the bottom rail. As shown in Fig. 26.
2. Insert spacers on either side of the glass in the bottom rail. Spacer will be flush with the side of the glass. As shown in Fig. 27.

Tip:

- Be sure to wear safety gloves & glasses when handling glass.

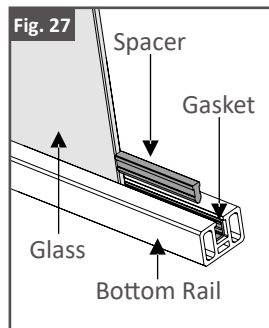
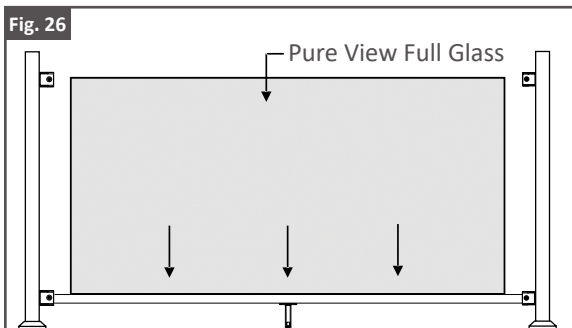

Step 4: Install Top Rail

1. Carefully slip Top Rail over the top of the glass into the top Bracket Cups.
2. Use a rubber mallet and a wood block to drive the top rail on to the glass. As shown in Fig. 29.
3. Pre-drill Bracket Cup holes for screws using a 3/16" [5mm] drill bit.
4. Secure top rail to Bracket Cups with provided T-25 Drive Thread-Cutting Screws. Use low speed setting on drill.

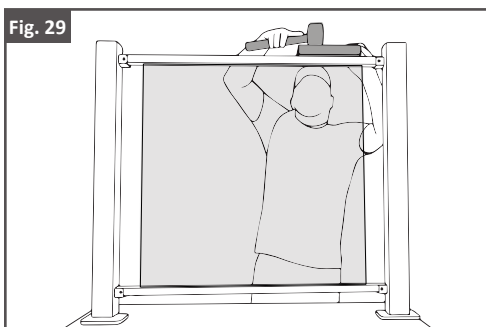
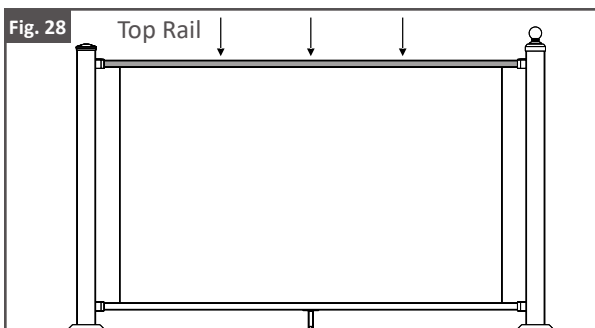

Step 5: Install Top Rail (Alternative)

1. Carefully slip Top Rail over the top of the glass into the top Bracket Cups.
2. Carefully slip Ratchet Straps over top rail and underneath bottom rail.
3. Slowly clamp each Strap until glass is fully seated in top rail. As shown in Fig. 30.
4. Pre-drill Bracket Cup holes for screws using a 3/16" [5mm] drill bit.
5. Secure top rail to Bracket Cups with provided T-25 Drive Thread-Cutting Screws. Use low speed setting on drill.

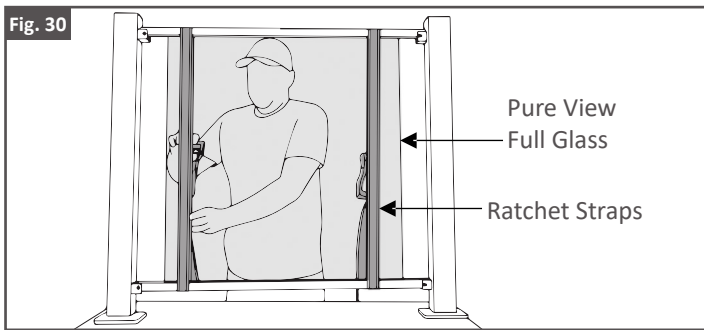

Step 6: Attach I-Support To Deck

1. Fasten I-Support to deck surface with the supplied Phillips Head Wood Screw.

Tip:

- Pre-drill with a 1/16" [5mm] drill bit.

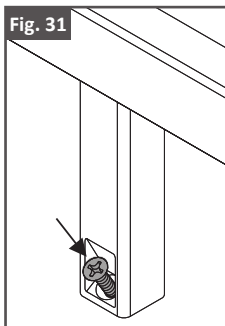

PROUD POST: ROUND ACCENT TOP RAIL (ATR)

Step 1: Round ATR Spacers

1. Attach Spacers using provided self-drilling screws with a 5/16" [8mm] nut driver, two screws per spacer. As shown in Fig. 33.
 - The Accent Top Rail Kit comes with 6 spacers in the 69.89" [1775mm] kit.
 - The spacers should be equally spaced along the length of the rail, with no more than 14" [356mm] spacing between them. As shown in Fig. 32.
 - The end spacers should be placed as close to the end brackets as possible.

Note:

- **DO NOT** remove backing of double sided tape until you are ready to permanently attach the ATR.

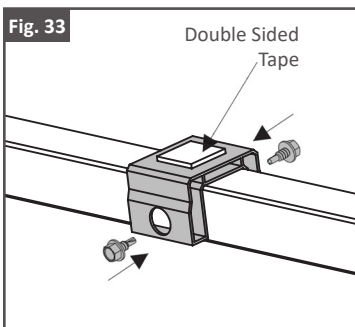
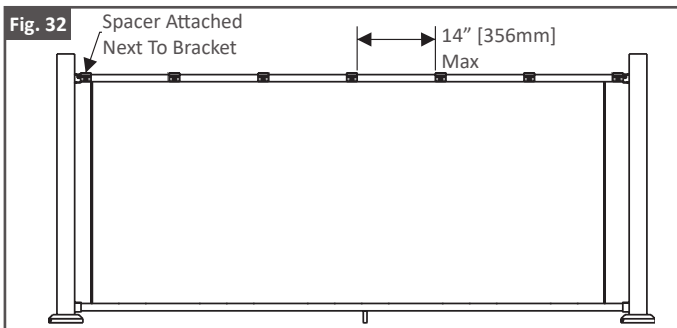

Step 2: Round ATR Line & End

1. Measure the distance from the inside edge of the 2 posts.
2. Cut the ATR to measured length.
3. When test fitting the ATR, place it on top of the spacers. **DO NOT** press the ATR down over the spacers. Removing the ATR from the spacers can damage the ATR and spacers. As shown in Fig. 35.
4. Remove the backing of all of the double-sided tape on the ATR spacers.
5. A Rubber Mallet might need to be used to install. If using a Rubber Mallet, use a cloth to protect ATR from damage.

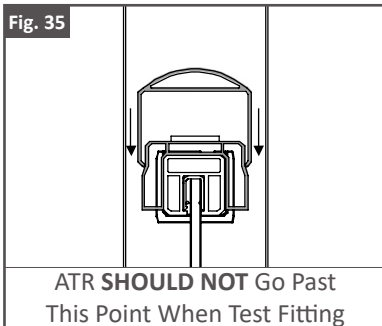
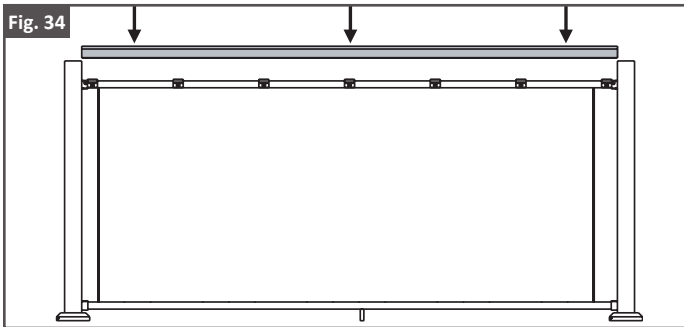

PROUD POST: FLAT ACCENT TOP RAIL (ATR)

Step 1: Flat ATR Spacers

1. Measure distance between brackets and cut ATR Spacer to length. The Spacer can be 1/4" [6mm] shorter than the distance between brackets.

2. If one of the screw holes was cut off during the sizing of the ATR Spacer, use a 5/8" [16mm] drill bit to add another hole 1" [25mm] from the end of the ATR Spacer.
3. Attach the ATR Spacer using the provided self-drilling screws with a 5/16" [8mm] nut driver.
4. All screw holes must have a screw installed.

Note:

- **Flat ATR uses a full length ATR spacer.**
- **DO NOT** remove backing of double sided tape until you are ready to permanently attach the ATR.

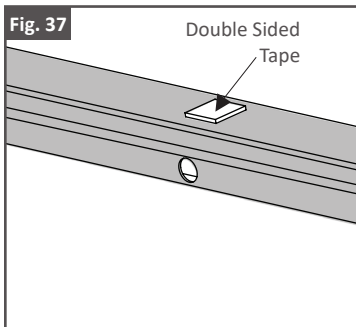
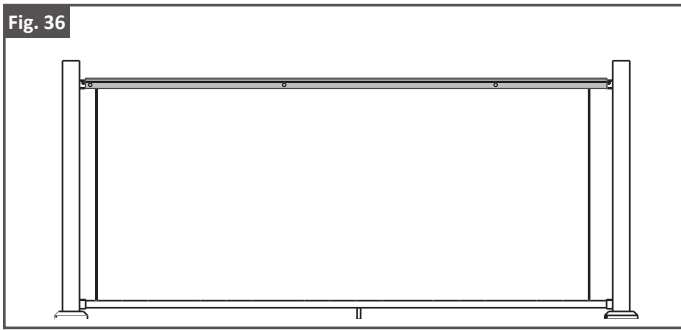

Step 2: Flat ATR Line And End

- Reference Proud Post Round ATR Line & End instructions on page 18.

OVER THE POST: ROUND ACCENT TOP RAIL (ATR)

Step 1: Round ATR Spacers

1. Attach spacers using provided self-drilling screws with a 5/16" [8mm] nut driver, two screws per spacer. As shown in Fig. 39.
 - The Accent Top Rail Kit comes with 6 spacers in the 69-7/8" [1775mm] kit.
 - The spacers should be equally spaced along the length of the rail, with no more than 14" [356mm] spacing between them. As shown in Fig. 38.
 - The end spacers should be placed as close to the end brackets as possible.

Note:

- **DO NOT** remove backing of double sided tape until you are ready to permanently attach the ATR.

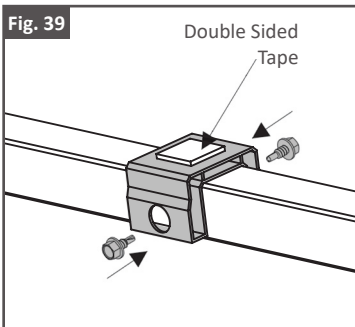
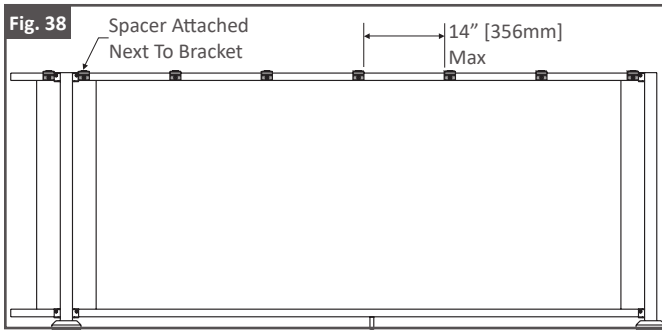

Step 2. Round ATR Line & End

1. Measure the distance from the inside edge of the 2 posts.
2. Cut the ATR to measured length.
3. The ATR cannot block the inside edge of the post. As shown in Fig. 42.
4. When test fitting the ATR, place on top of the spacers. **DO NOT** press the ATR down over the spacers. Removing the ATR from the spacers can damage the ATR and spacers. As shown in Fig. 41.
5. Remove the backing of all of the double-sided tape on the ATR spacers.
6. A Rubber Mallet might need to be used to install. If using a rubber mallet, use a cloth to protect the ATR from damage.

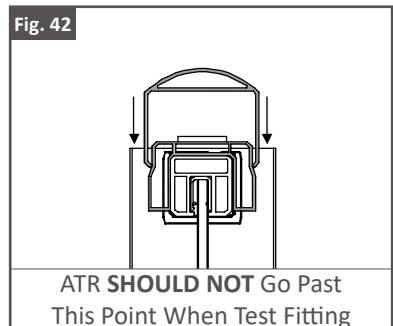
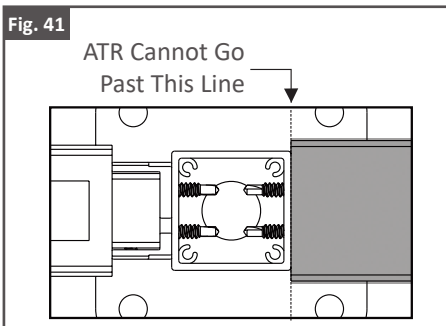
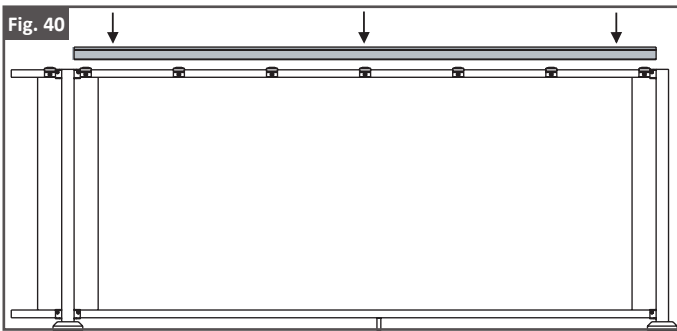

Step 3: Round ATR Corner

1. When installing ATR on corners with a 2" [51mm] post, the ATR must be 5/16" [8mm] away from the post. As shown in Fig. 43.
2. If installing a corner with a 3" [76mm] proud post, install the ATR at full length from the inside edge of the post to the inside edge of the post.

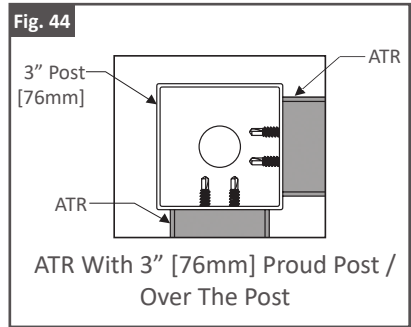
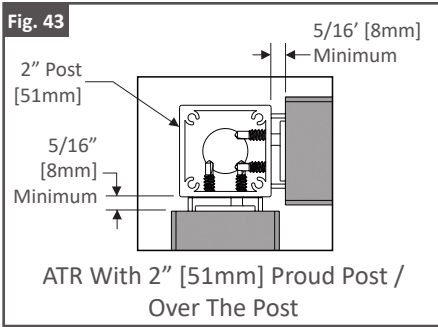

Step 4: Round ATR Splice

1. To install an ATR splice: Center the splice over the post and with force press down over the ATR. As shown in Fig. 45, 46, 47.
2. A Rubber Mallet might need to be used to install. If using a Rubber Mallet, use a cloth to protect the splice from damage.
 - ATR splices reference the inside of the post and snap down around the ATR.
 - ATR splices allow up to 1/2" [12.5mm] of length variation from the edge of the post. As shown in Fig. 48, 49, 50.

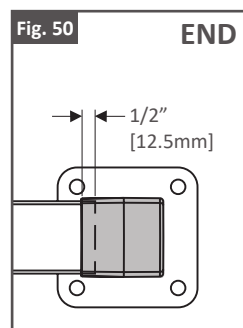
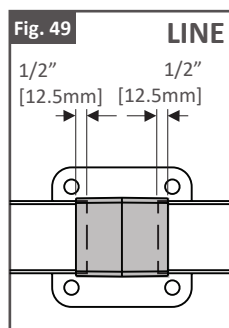
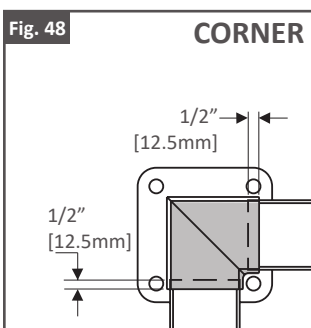
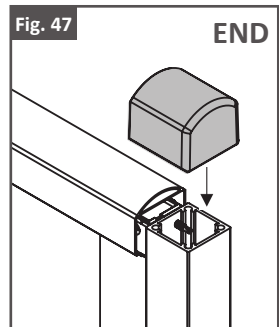
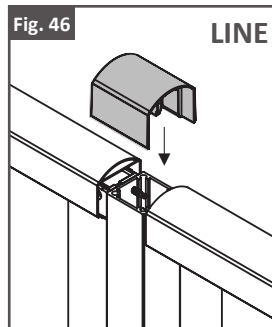
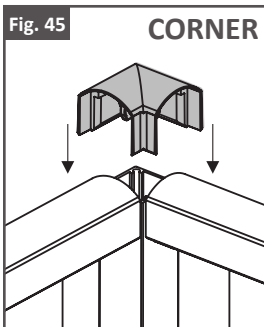

OVER THE POST: FLAT ACCENT TOP RAIL (ATR)

Step 1: Flat ATR Spacers

1. Measure distance between brackets and cut ATR spacer to length. The spacer can be 1/4" [6mm] shorter than the distance between brackets.
2. If one of the screw holes was cut off during the sizing of the ATR spacer, use a 5/8" [16mm] drill bit to add another hole 1" [25mm] from the end of the ATR spacer.
3. Attach the ATR spacer using the provided self-drilling screws with a 5/16" [8mm] nut driver.
4. All screw holes must have a screw installed.

Note:

- **Flat ATR uses a full length ATR spacer.**
- **DO NOT** remove backing of double sided tape until you are ready to permanently attach the ATR.

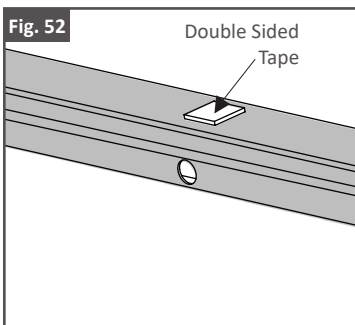
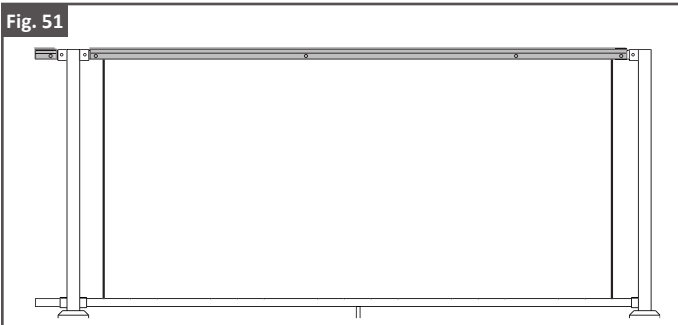

Step 2: Flat ATR Line & End

- Reference OTP Round ATR Line & End instructions on page 21.

Step 3: Flat ATR Corner

- Reference OTP Round ATR Corner instructions on page 21.

Step 4: Flat ATR Splice

- Reference OTP Round ATR Splice instructions on page 22.

PROUD POST & OTP: BRACKET CAP, POST CAP & POST BASE COVER INSTALLATION

Step 1: Install Bracket Caps

1. The Bracket Covers snap down into place.
2. Use a Rubber Mallet to snap the bracket covers in place.

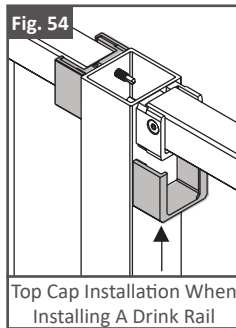
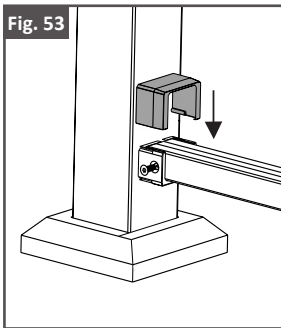

Step 2: Install Post Caps

1. AI¹³ HOME Posts Caps are press fit into place.
2. Use a Rubber Mallet to snap the caps in place.

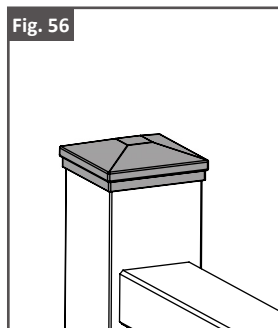
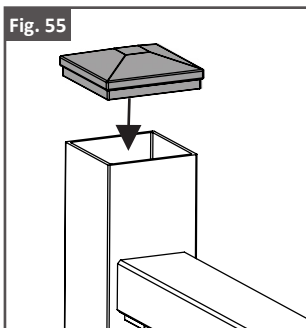

Step 3: Install Post Base Covers

1. Separate the two-piece base plate cover. Hold one side parallel to the post base plate. As shown in Fig. 57.
2. Place 2nd half of the post base cover on the opposite side of the post. Hold 2nd piece slightly under the 1st piece. As shown in Fig. 58.
3. Twist the 2nd cover ¼ turn and move piece until both half's touch. As shown in Fig. 59.
4. Make sure one of the locking pins on the 2nd cover engage with the proper slot on the 1st cover piece. As shown in Fig. 60.
5. Once the first locking pin is started, turn the 2nd cover piece back parallel to the post base plate. Once you have confirmed both locking pins have engaged with the opposing slots lower both half's over the post base plate. As shown in Fig. 61.

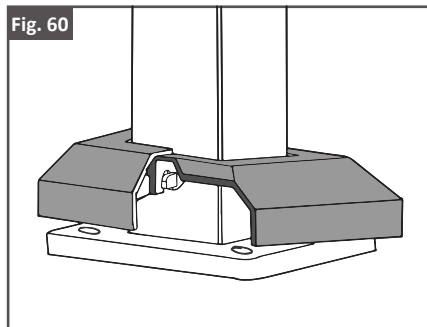
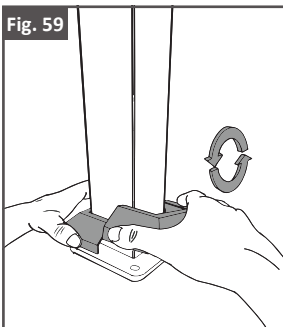
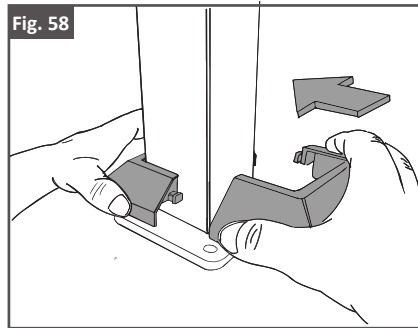
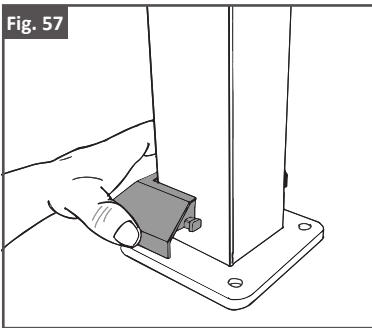
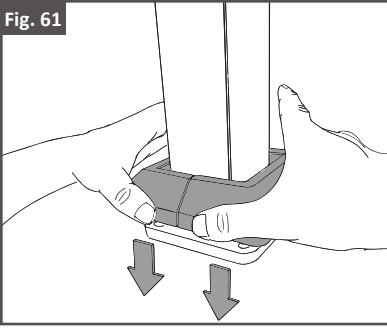

Fig. 61



ANGLE BRACKET

Pure View: AI¹³ HOME Full Glass Panel Angle Bracket Installation Options

2" [51mm] or 3" [76mm] Proud Post

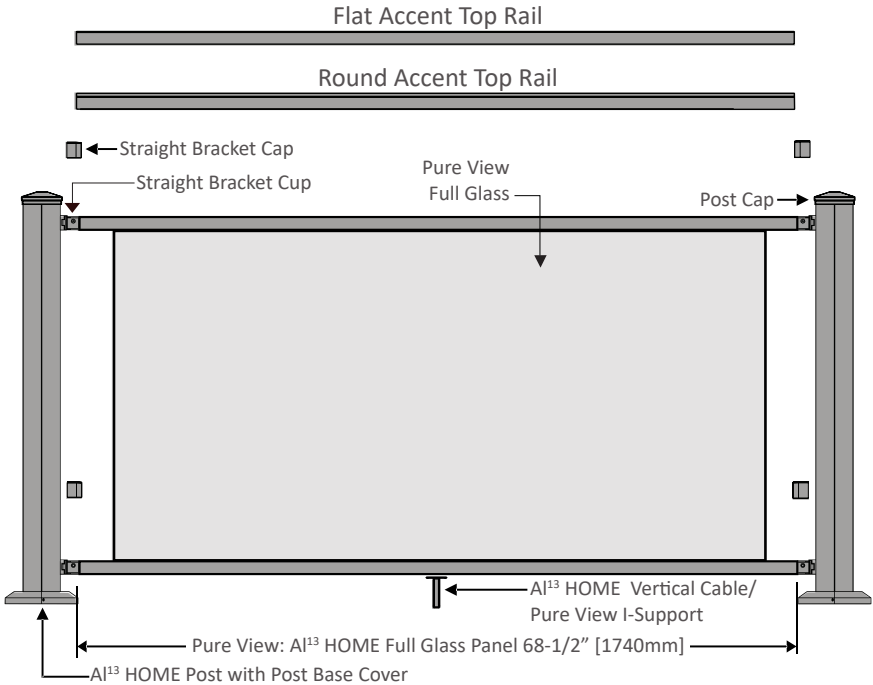

2" [51mm] or 3" [76mm] Proud Post Configurations

**AI¹³ HOME
Panel Height**

32-1/2" [826mm]

40" [1016mm]

Rail Panel

Installed Panel Height

36" [914mm]

42" [1067mm]

Required Post

39-1/2" [1003mm]

45-1/2" [1156mm]

*Installed heights include a 3-1/2" [89mm] for the 32-1/2" [826mm] panel & 2" [51mm] for the 40" [1016mm] panel space between deck surface and bottom edge of bottom rail.

2" [51mm] Over The Post (OTP)

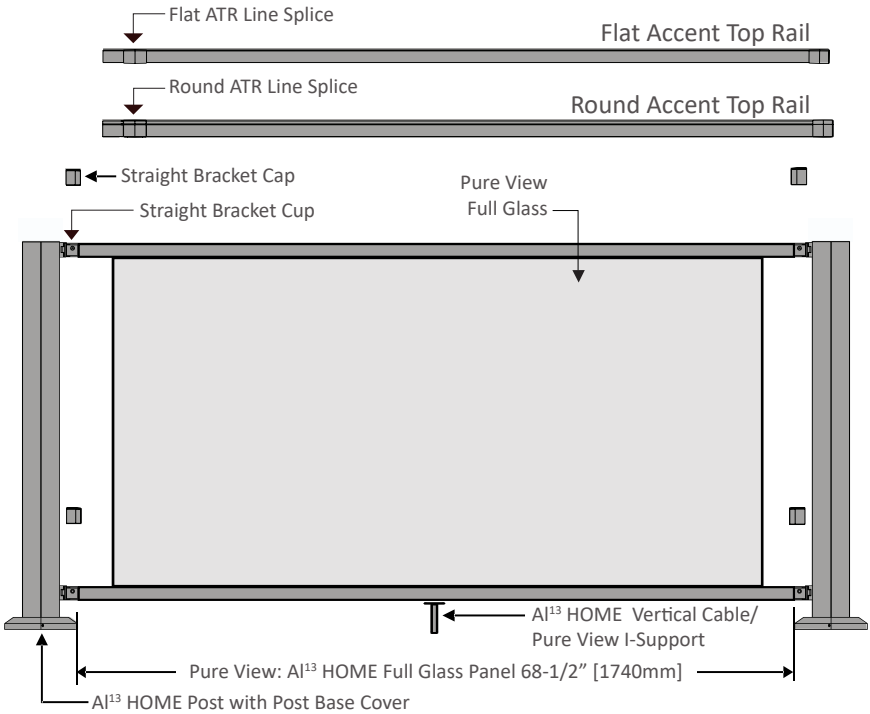

2" [51mm] Over The Post (OTP) Configurations		
Al ¹³ HOME Panel Height	Rail Panel	
	Installed Panel Height	Required Post
32-1/2" [826mm]	36" [914mm]	36" [914mm]
40" [1016mm]	42" [1067mm]	42" [1067mm]

*Installed heights include a 3-1/2" [89mm] for the 32-1/2" [826mm] panel & 2" [51mm] for the 40" [1016mm] panel space between deck surface and bottom edge of bottom rail.

ANGLE BRACKET: POST MOUNTING

- Reference Post Mounting instructions on page 6.

Note:

IT'S RECOMMENDED TO INSTALL BRACKETS ON TO POST BEFORE POST MOUNTING.

ANGLE BRACKET: BRACKET INSTALLATION

Step 1: Mark Bracket Hole Locations

1. Mark the centerline of each post with a pencil.
2. Take measurements used in Fig. 62 and 63 to mark bottom and top bracket hole locations onto posts.

Note:

- Installed panel heights include space between the deck surface and underside of bottom rail. AL¹³ HOME 32-1/2" [826mm] panels have a 3-1/2" [89mm] space. AL¹³ HOME 40" [1,016mm] panels have a 2" [51mm] space.

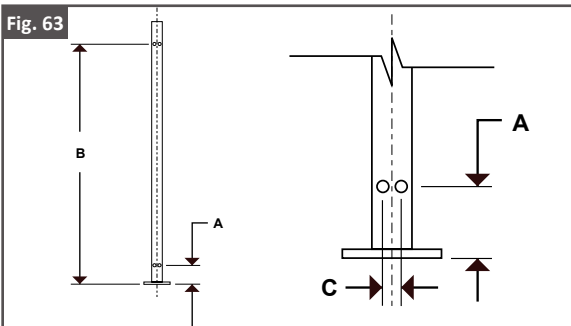
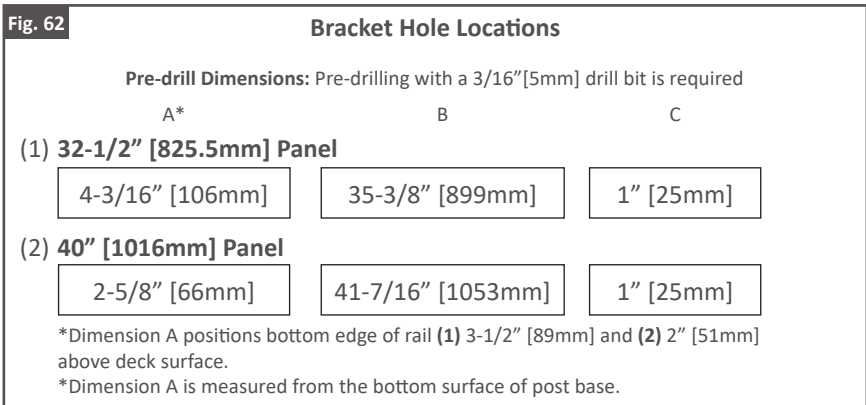

Step 2: Pre-Drill Aluminum Angle Brackets

Tip:

- It's important to double check dimensions to confirm accuracy of bracket hole locations before drilling.

1. Use Spring Punch to mark the holes. As shown in Fig. 64.
2. Pre-drill bracket holes with a 3/16" [5mm] drill bit. As shown in Fig. 65.
3. Remove the bolt from the Aluminum Angle Bracket Assembly.

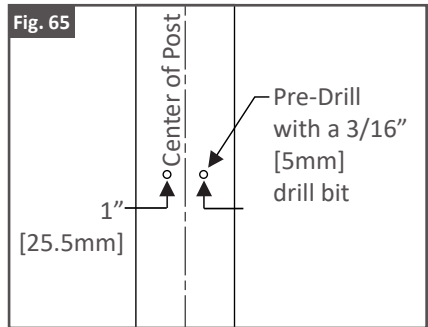
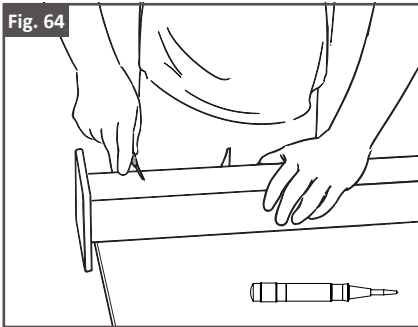

Step 3: Install Aluminum Angle Brackets

1. Attach Aluminum Angle Bracket Base piece to the posts with supplied T-25 thread-cutting screws. Use two screws per bracket. Use low speed setting on drill. The side of the base with two holes should be facing downwards. As shown in Fig. 66.
2. Reassemble the Aluminum Angle Brackets, but **DO NOT** install the Angle Bracket Cap at this time. As shown in Fig. 67.
3. Once top and bottom brackets are installed, remeasure bracket spacing to confirm dimensions used in Fig. 62 and 63 of step 1.
4. Remove all metal shavings from deck, post base cover, post, and panel before bracket is screwed to post.

Tip:

- Use a Bit Extender for an easier drilling process.

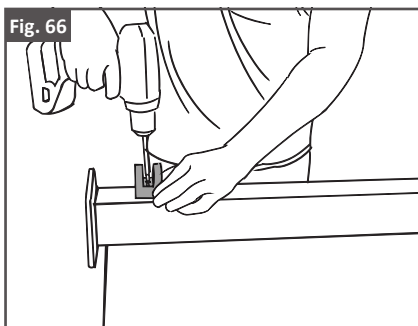
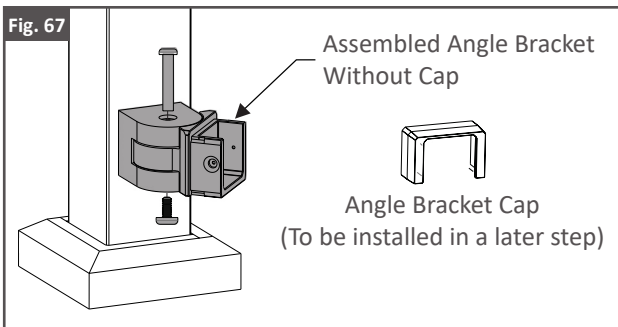

Fig. 67



Step 3: Determine Panel Length

1. Check to ensure that all posts are square and straight. Shim posts as required.
2. Ensure that the Angle Bracket Cups are approximately aligned.
3. With another person's help, measure the distance from the inside back of one cup to the inside back of the other cup. This will be the panel length. As shown in Fig. 69.

Fig. 68

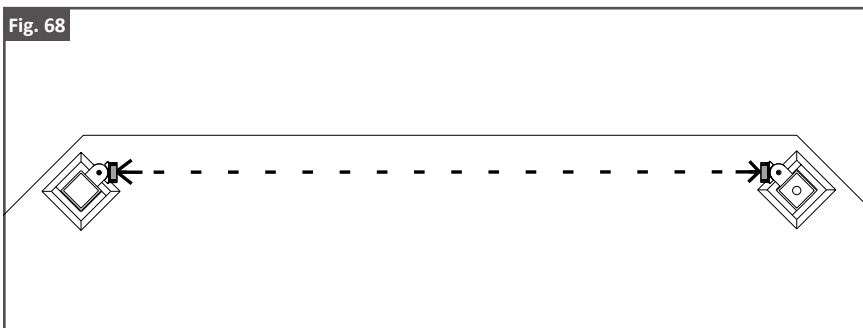
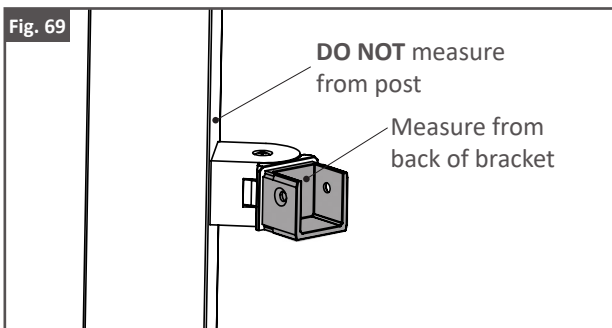

Fig. 69



ANGLE BRACKET: CUTTING DOWN TOP & BOTTOM RAILS

- Reference pages 11 - 13 for Rail Cutting steps.

ANGLE BRACKET: FULL GLASS PANEL INSTALLATION

- Reference Full Glass Panel installation instructions on pages 13 - 16.

ANGLE BRACKET: ROUND & FLAT ACCENT TOP RAIL (ATR)

- Reference page 17-19 for Proud Post ATR steps.
- Reference page 20-24 for OTP ATR steps.

ANGLE BRACKET: ROUND & FLAT ATR MITER SPLICE

Step 1: ATR Angle Splice (Proud Post)

1. Use 3/32" [2.5mm] hex wrench to tighten set screw and lock Angle Bracket at 45° degree position.
As shown in Fig. 70 and 71.
2. Place Angle Splice on top of ATR butting up the end face of the splice to the face of the 3" [76mm] post.
As shown in Fig 72 and 73.
3. A Rubber Mallet might need to be used to install. If using a Rubber Mallet, use a cloth to protect the ATR from damage.
4. Secure Angle Splice with two #6-20 x 1/2" [13mm] self-drilling screws.

Note:

- **Angle Splice only work if brackets are angled at the 45° degree setting.**

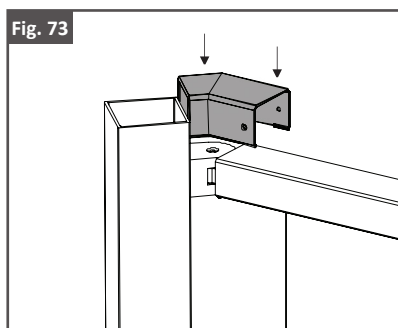
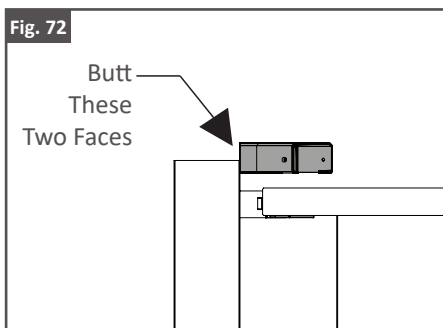
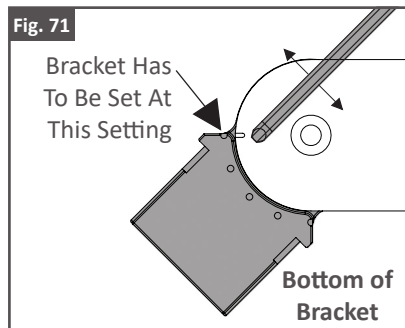
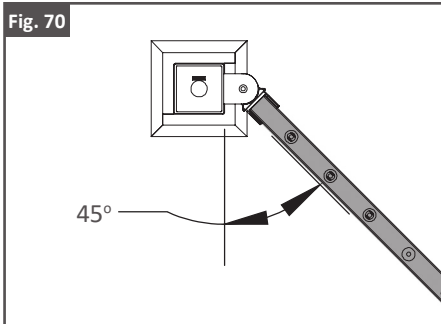

Step 2: ATR Angle Splice (OTP)

1. Install ATRs and Spacers opposite of the Angle Bracket first.
2. Measure from the inside of the post and add 2" [51mm] to the over all length.
3. Install ATRs and Spacers on the Angle side measuring from the end of the Bracket Cup adding 2-1/2" [64mm] to the overall length.
4. Once both ATRs are installed center Angle Splice over Angle Bracket.
5. Secure Angle Splice on ATRs with a Rubber Mallet.

Note:

- ATR should overhang Post 1" [25mm] in each side.

Fig. 74

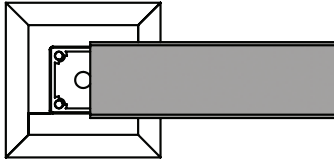

ATR Should Over Hang on Post
1" [25mm] on Both Sides

Fig. 75

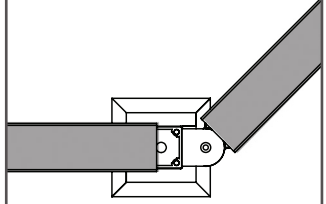

Fig. 76

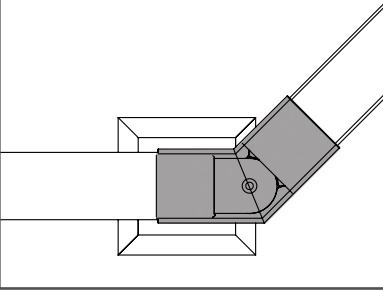
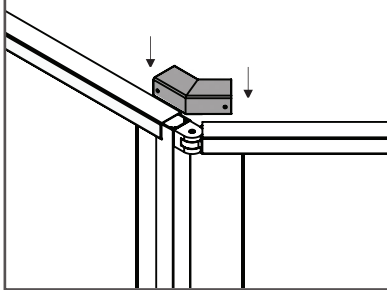

Fig. 77



ANGLE BRACKET: BRACKET CAP, POST CAP & POST BASE COVER INSTALLATION

- Reference Bracket Cap, Post Cap & Post Base Cover installation instructions on pages 24 - 26.

CARE & MAINTENANCE

Care And Maintenance of Fortress Railing Products Powder-Coated Products And Surfaces:

- After installation of your Fortress Building Product, clean powder-coated products and surfaces with a solution of warm water and non-abrasive, pH neutral detergent solution. Surfaces should be thoroughly rinsed after cleaning to remove all residues. All surfaces should be cleaned using a soft cloth or sponge. Examples of acceptable cleaners are Simple Green, dish soap and warm water.
- Ensure construction materials such as concrete, plaster, and paint splashes are removed immediately before they have a chance to dry. Failure to remove these materials may cause damage to the powder-coated surfaces.
- The frequency of cleaning depends in part on the standard of appearance and also the requirements to remove deposits that may cause damage to the powder coating after prolonged exposure. Fortress recommends cleaning in three to four monthly intervals all products and powder-coated surfaces. In areas where higher traffic, increased atmospheric substances, or other effects may occur, the time period between cleanings should be increased to monthly intervals.
- **WARNING: DO NOT use strong solvents such as thinners, or solutions containing chlorinated hydrocarbons, esters, or ketones. Abrasive cleaners or cutting compounds should not be used.**

WARRANTY

To obtain and review a copy of the warranty, please go to: <https://Fortressbp.com/warranties>. You can also contact: (844) 909-1999 or write to: Fortress Building Products Warranty, 1720 N 1st St, Garland, TX 75040 to obtain a copy of the warranty.



JOIN THE REVOLUTION.

FortressBP.com | 866.323.4766