

EVOLUTION[™]

STEEL PERGOLA

TABLE OF CONTENTS

Introduction

General Guidelines.....	3
Required Tools/Components.....	4

Installation

Project Planning.....	6
Cutting & Painting.....	7
Pergola Connections	
Post to Foundation.....	9
Post to Framing Member.....	11
Post to Framing Member (F-50 Bracket).....	11
Post to Framing Member (Rafter Hanger Bracket).....	12
Post to Single or Double Beam Joists.....	13
Post to Material (Composites, Lumber, Joists etc).....	14
Lateral Bracing Assembly.....	15
Rafter to Framing Member (F-50 Bracket).....	17
Rafter to Framing Member (Single or Double Hanger Bracket).....	19
Rafter to Framing (Rafter Hanger Bracket)	21
Single or Double Beam Joist To Rafter.....	22
Rafter To Purlin.....	23
Rafter Tail to Post/ Rafter.....	24
Joist/Framing Member Cap.....	26
Purlin Cap.....	27
Post Cap.....	27
Care & Maintenance/Warranty.....	29

INTRODUCTION

READ INSTRUCTIONS COMPLETELY BEFORE STARTING INSTALLATION

General Guidelines

It is the responsibility of the installer to meet all code and safety requirements, and to obtain all required building permits. The pergola installer should determine and implement appropriate installation techniques for each installation situation. Neither Fortress Building Products nor its distributors shall not be held liable for improper or unsafe installations.

Personal Protection Equipment (PPE) must be worn anytime you're using power tools and working with Modern Pergola. Eye protection, hearing protection, closed-toe shoes, gloves, long sleeves, and pants must be worn to keep yourself safe.

As the steel parts are cut, all metal shavings and/or chips must be removed from inside the pergola parts. At the end of each day all steel shavings and/or chips must be cleaned off the job site. Not doing so could result in the staining of surrounding surfaces.

As the steel parts are cut, **DO NOT** allow metal shavings and/or chips to get dropped or blown into a pool, hot tub, or any other body of water. Staining could occur if this were to happen.

Fortress Building Products does not cover all possible installation scenarios within these instructions. In some cases, it may be necessary for you to consult a professional engineer, building code official, or local dealer. In addition, it may become necessary to use brackets other than Fortress' when more complex installations take place.

Required Tools

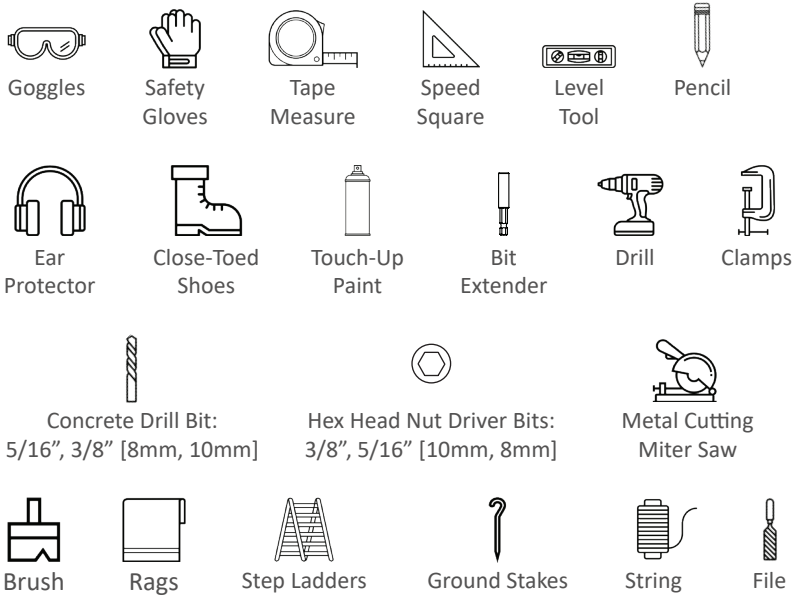

Components

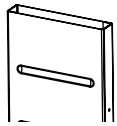

Beam

2" x 11" x 8', 12', 16' or 20'
[51mm x 279mm x 2438mm,
3658mm, 4877mm or 6096mm]

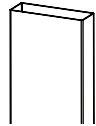

Joist (Framing Member or Rafter)

2" x 6" x 12', 14', 16', 18' or 20'
[51mm x 152mm x 3658mm, 4267mm,
4877mm, 5486mm, 6096mm]

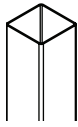

Post

3-1/2" x 3-1/2", 5-1/2" x 5-1/2", 7" x 7", x 8'
[89mm x 89mm, 140mm x 140mm,
178mm x 178mm, x 2438mm]



Purlin or Lateral Bracing Support

2" x 2" x 10'
[51mm x 51mm x 3048mm]

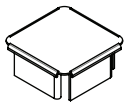

Purlin Cap

2" x 2" [51mm x 51mm]

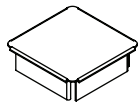

Post Cap

3-1/2" x 3-1/2", 5-1/2" x 5-1/2", 7" x 7"
[89mm x 89mm, 140mm x 140mm, 178mm x 178mm]

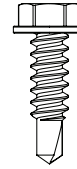

Evolution Self-drilling Screw

3/4" [19mm]
#12

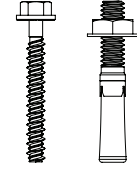

Anchor (NOT PROVIDED BY FORTRESS)
Concrete Anchor: 3/8" x 3" [10mm x 76mm]
Wedge Anchor: 3/8" x 3" [10mm x 76mm]

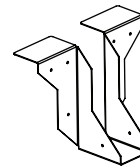

Single Hanger Bracket

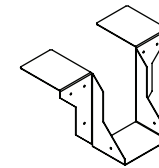

Double Hanger Bracket

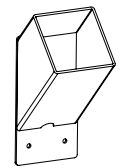

Lateral Bracing Bracket

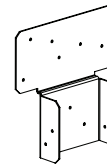

Double Beam To Post Bracket

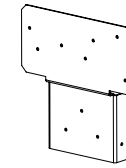

Single Beam To Post Bracket

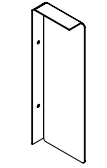
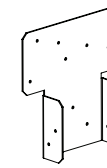

Joist Cap

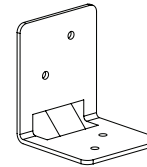

F-10 Bracket

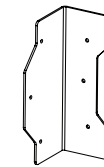

F-50 Bracket

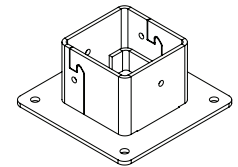

Post Anchor Bracket

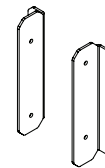

CS Bracket

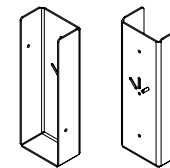

Rafter Hanger Bracket

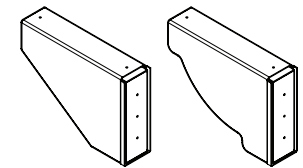

**Rafter Tails
(45° Degree or Arched)**

Note:

The Evolution Pergola can be assembled using various connection combinations. These instructions cover possible connections that can be used for a pergola installation.

Visit <https://fortressbp.com/pergolas> for inspiration on potential pergola designs.

PROJECT PLANNING

Step 1: Create a Perimeter For The Pergola

1. Using Stakes and Guide String, create a perimeter for the pergola. Each Guide String should be positioned a minimum of 4" [102mm] from the edge of the foundation. As shown in Fig. 1.

Tip:

- Before starting the pergola project, confirm that the pergola foundation is level and square. Consult with your local building code officials for foundation requirements.
- Be sure corners are set at 90° angles.

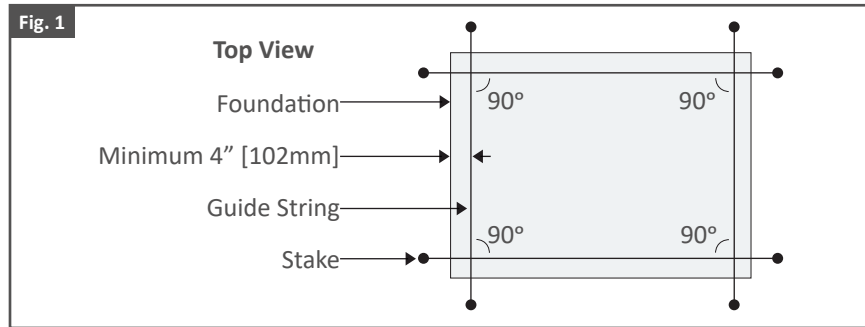

Step 2: Mark Post Anchor Bracket Locations

1. Position Post Anchor Brackets along internal corners of Guide Strings. As shown in Fig. 2.
2. Using a pencil, mark bolt hole locations.

Tip:

- **For a successful installation, confirm the created perimeter with Post Anchor Brackets is accurate and square.**
- **How To Square Perimeter:** Fortress recommends using the 3-4-5 rule. Measure and mark 3' [914mm] & 4' [1219mm] from the starting point along guide string, then measure between two markings. Adjust until measurement between markings is exactly 5' [1524mm]. As shown in Fig. 2. Larger triangles, with sides of 6-8-10 and 9-12-15, allow for even more accurate results.

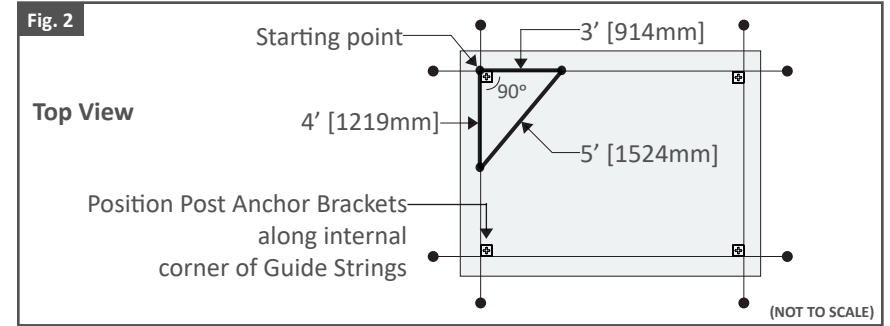

CUTTING & PAINTING

Step 1: Mark Cut Points

1. Position the Post, Joist (Framing Member or Rafter) or Purlin on a flat surface.
2. Using a pencil, mark desired length onto material being cut.
3. Using a Speed Square, straighten cut point markings on top and side faces. As shown in Fig. 3.

Tip:

- Before making cuts, confirm cut length is correct.

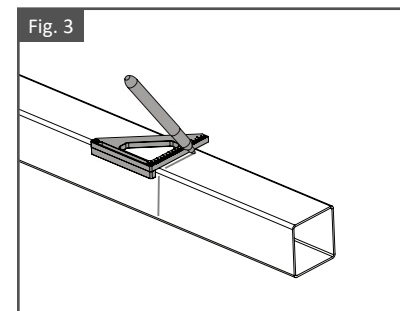

Step 2: Cut The Material

1. Cut the Post, Joist or Purlin using a Portable Band Saw, Metal Cutting Circular Saw or Grinder with a cutoff disc. As shown in Fig. 4. Be sure to follow cut marks.

Tip:

- Be sure the material is supported when cutting to prevent bending or binding.
- Be sure to not over heat the material when making cuts with a grinder.

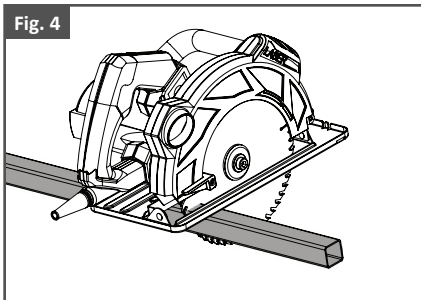

Step 3: Clean Cut Areas & Apply Spray Paint To Cut Areas

1. Use a file to smooth cut edges. As shown in Fig. 5.
2. Remove any metal shavings and dust with a brush or rag.
3. Make sure surfaces to be painted are clean. **DO NOT** cut product over concrete. Be sure to remove any metal shavings to avoid stains.
4. Using a piece of cardboard as a mask, apply the 1st coat of Fortress Black Sand Touch Up Paint.
5. Allow to dry before applying second coat.
6. Apply the 2nd coat of Fortress Black Sand Touch Up Paint. A minimum of three coats of spray paint will be required for installations within a mile of coastal regions.
7. Allow to dry and install.

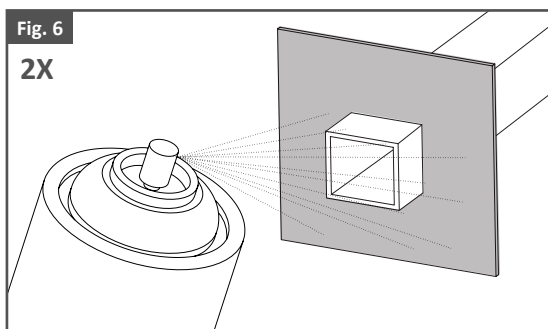
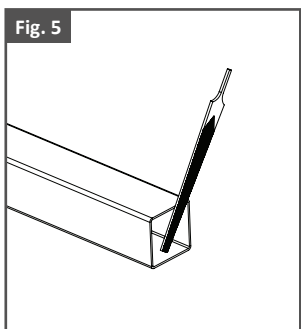

PERGOLA CONNECTIONS

Connection 1: Post To Foundation

1. Cut Posts to desired height. Reference cutting and painting instructions on pages 7 & 8.
2. Place Post Anchor Bracket in desired position on concrete or slab.
3. Mark four bolt hole locations As shown in Fig. 7.
4. Pre-drill holes using a concrete drill bit. Reference the relevant concrete anchor manufacturer for recommended drill bit size.
5. Mount the Post Anchor Bracket onto the surface using concrete anchors. As shown in Fig. 8.
6. Remove the Post Anchor Bracket detachable cover by lifting it up and out of the bracket slot. As shown in Fig. 9.
7. Insert Post into Post Anchor Bracket. Be sure post is fully inserted and resting on standoff blocks in the bracket. As shown in Fig. 10.
8. Mount the Post Anchor Bracket detachable cover back onto the bracket slot. As shown in Fig. 11. Confirm that the post is level and plumb. Adjust as needed.
9. Fasten Post into Post Anchor Bracket using Hex Head M6x25.4mm Self-Drilling screws. As shown in Fig. 12. Continuously check if post is level and plumb.

Note:

- **It is critical for Posts and Post Anchor Brackets to maintain the 90° angles established in project planing instructions on page 6.**

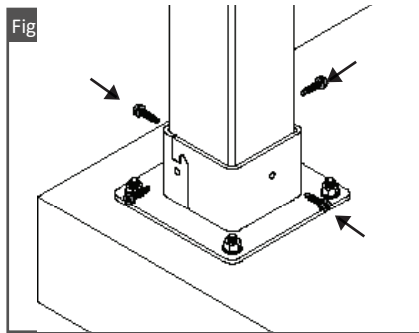
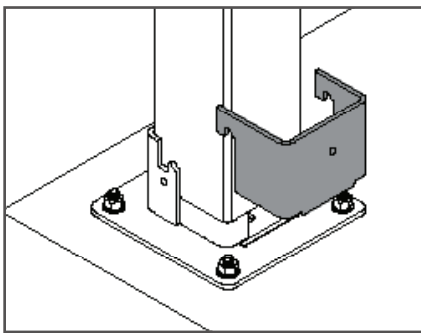
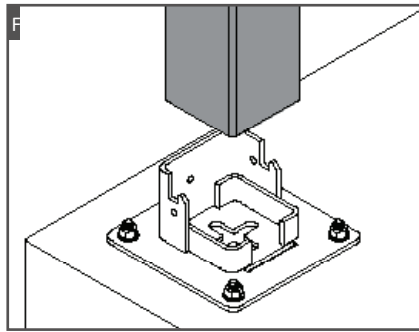
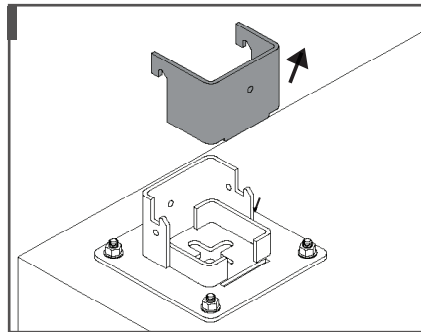
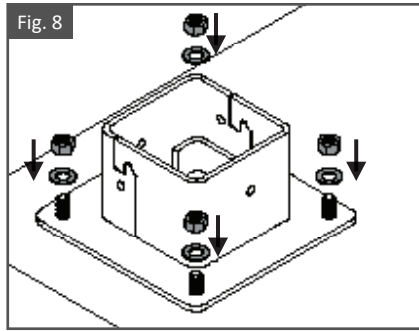
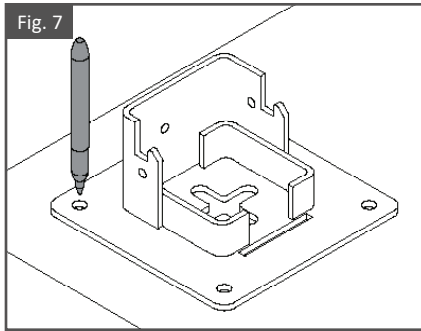

Connection 15: Post Cap

1. Position the Post Cap onto the exposed end of Post. As shown in Fig. 13 & 14. If required, use a Rubber Mallet to fully seat the Cap.
2. Using an Evolution Self-drilling Screw, fasten Cap onto the Post. As shown in Fig. 15 & 16. Position the screw 11/16" [18mm] from the end of the cap.

Note:

- The screw in Fig 15 & 16 might need to be removed when installing brackets.

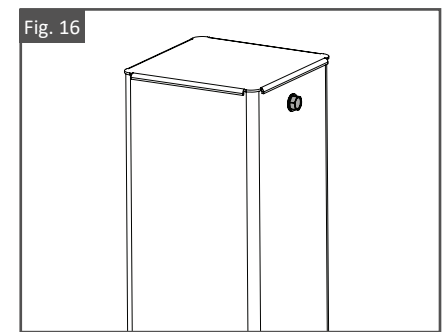
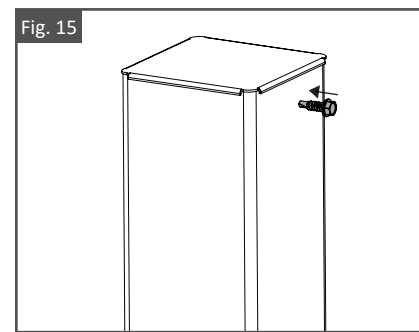
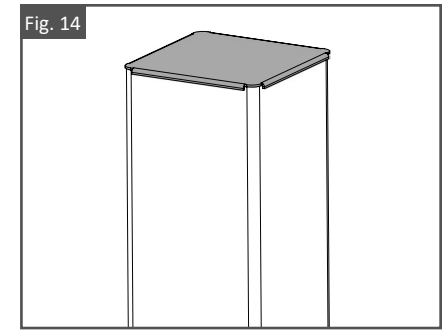
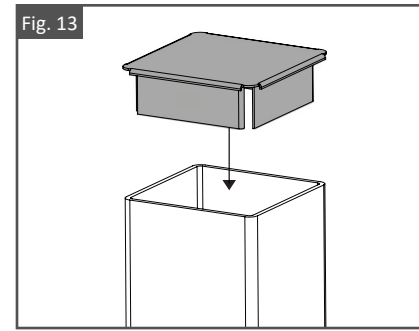

Connection 2: Post To Framing Member

1. Position F-50 Bracket flush to the outside edge of the Post and offset 7/16" [11mm] from the top face of the Post. As shown in Fig. 17.
2. Using Evolution Self-drilling Screws, mount the F-50 Bracket onto the Post. As shown in Fig. 18.
3. Position the Framing Member flush with the top face of the Post.
4. Using Evolution Self-drilling Screws, mount the F-50 Bracket onto the Framing Member. As shown in Fig. 19.
5. Alternatively, the F-50 Bracket can be flipped and installed facing the inside of the Framing Member. As shown in Fig. 20 & 21.

Note:

- Be sure drainage holes on the Framing Member face down once installed. As shown in Fig. 22. Adjust if required.

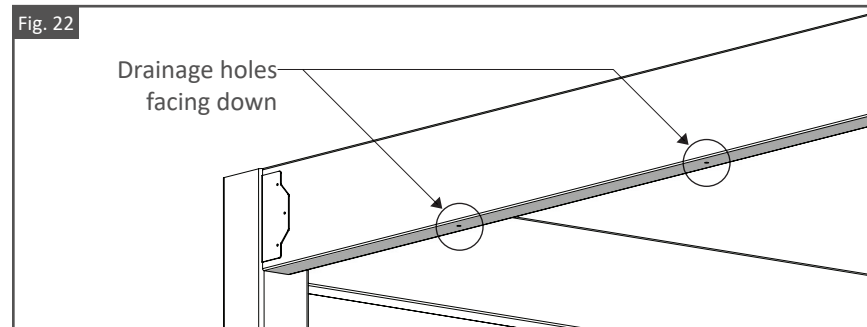
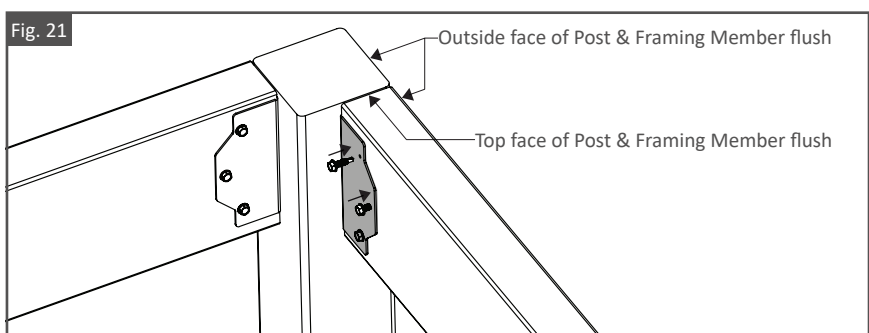
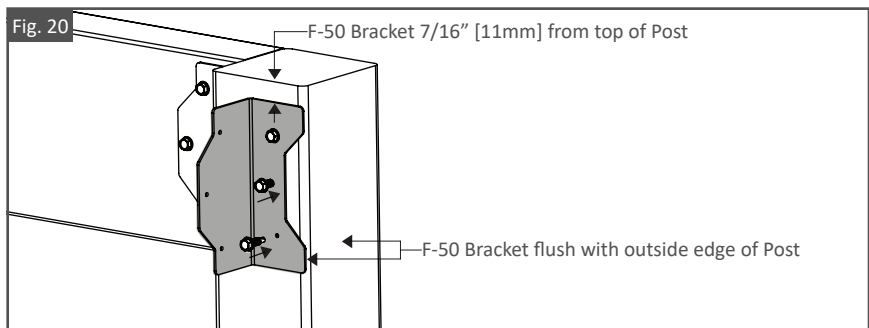
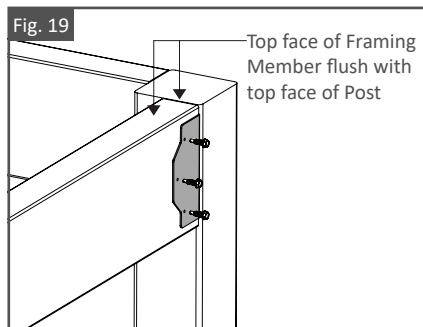
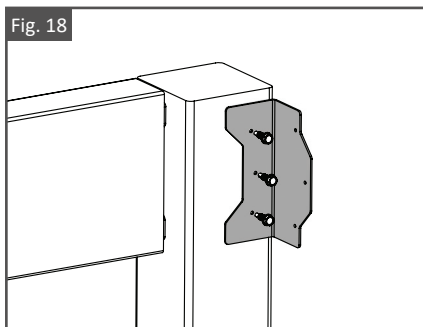
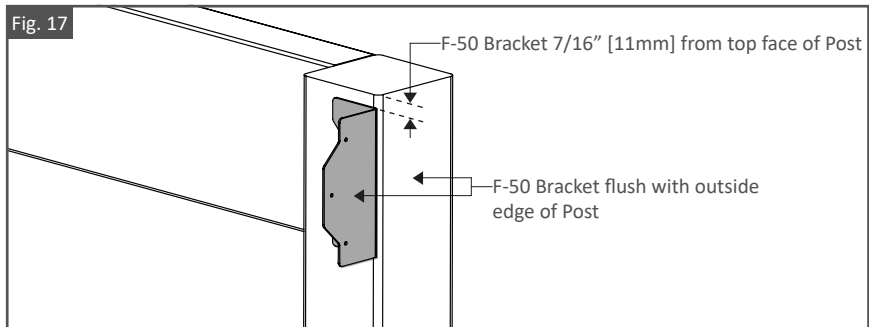

Connection 3: Post To Framing Member (Rafter Hanger Bracket)

Post to Framing Member:

1. Place a Rafter Hanger Bracket in desired position on two opposite Posts. **Offset Bracket 1/16" [2mm]** from the top of each Post. As shown in Fig. 23.
2. Using Evolution Self-drilling Screws, mount the Rafter Hanger Brackets onto the Post. As shown in Fig. 24. Use a Speed Square to keep bracket plumb when fastening.
3. Insert the Framing Member into the Rafter Hanger Brackets. As shown in Fig. 25.
4. Using Evolution Self-drilling Screws, fasten the Rafter Hanger Brackets onto the Framing Member. As shown in Fig. 26.

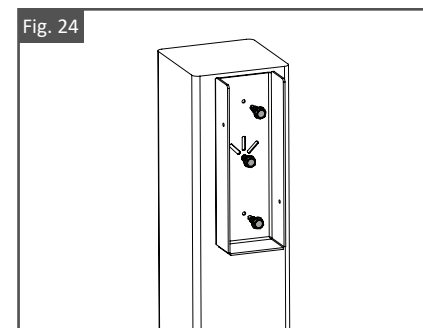
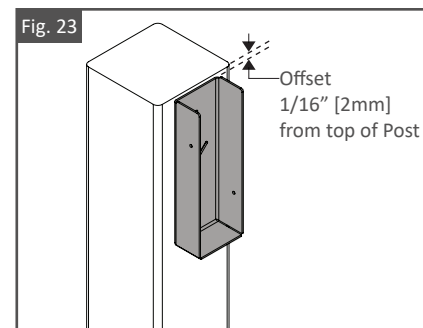

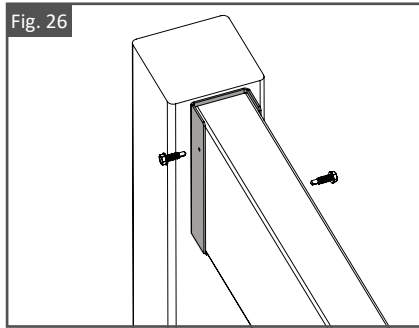
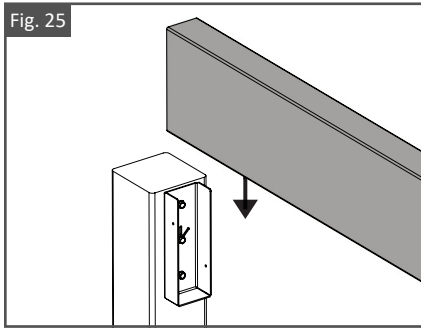

Connection 4: Post To Single or Double Beam Joists

1. Using Evolution Self-drilling Screws, fasten two Single or Double Beam to Post Brackets onto top edge of Post. As shown in Fig. 27.
2. Position Joists into desired location. For Double Beam Joists, be sure to have ends of Joists flush. As shown in Fig. 28.
3. While keeping Joists in position, fasten the Single or Double Beam to Post Brackets onto joists. As shown in Fig. 29.

Note:

- The maximum Joist to Post overhang allowed is 24" [610mm]. As shown in Fig. 30.

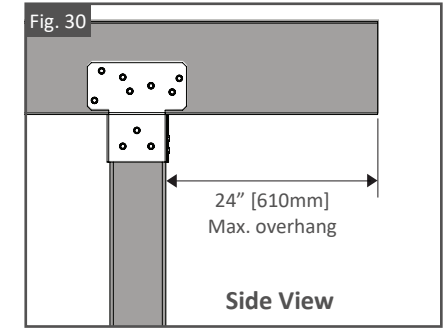
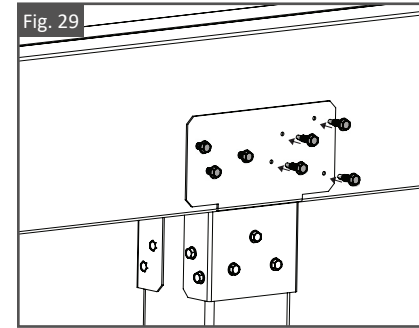
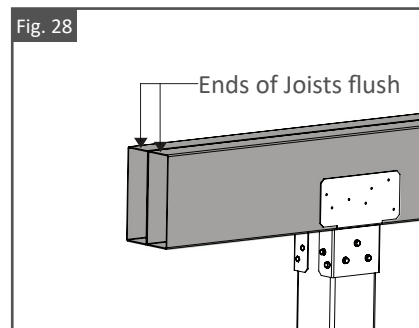
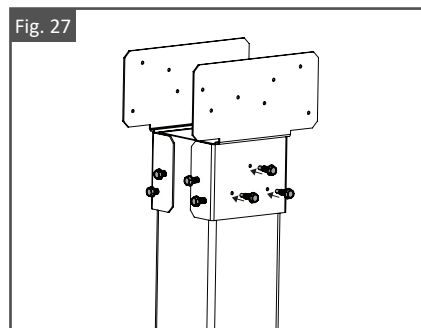

Connection 5: Privacy Screen - Material (Composites, Lumber, Joists etc) to Post

1. Cut material to desired length.
2. Using Evolution Self-drilling Screws, fasten two CS Brackets at both ends of cut material. Be sure outside face of bracket and material are flush. As shown in Fig. 31.
3. Place cut material assembly in desired position between two posts. Confirm assembly is level.
4. Using Evolution Self-drilling Screws, fasten CS Brackets onto posts. As shown in Fig. 32.

Note:

- Brackets are designed to be used with materials 1" [25mm] - 2" [51mm] in width.

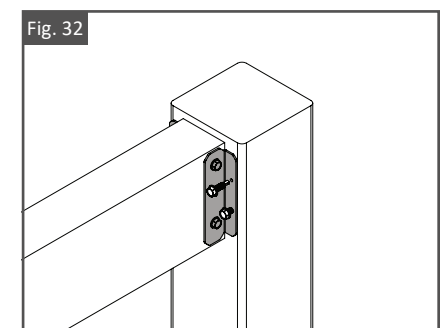
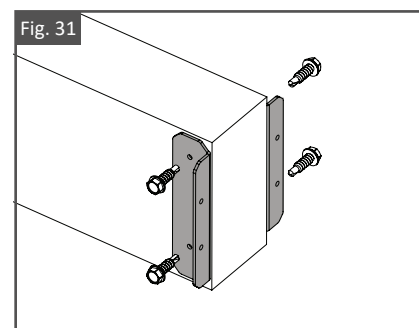

Connection 6: Lateral Bracing Assembly

1. Cut the 2" x 2" [51mm x 51mm] Lateral Bracing Support to desired length.
2. Cut both ends of the 2" x 2" [51mm x 51mm] Lateral Bracing Support at a 45° angle. As shown in Fig. 33. Reference pages 7 & 8 for cutting and panting instructions.
3. Insert the Lateral Bracing Brackets into both ends of the cut 2" x 2" [51mm x 51mm] Lateral Bracing Support. As shown in Fig. 34.
4. Be sure the Lateral Bracing Brackets are orientated in correct direction on the Lateral Bracing Support with the bracket flange facing away from the angle. As shown in Fig. 35. Adjust if needed.
5. Using two Evolution Self-drilling Screws, fasten the Lateral Bracing Brackets onto the cut 2" x 2" [51mm x 51mm] Lateral Bracing Support. Position the first screw centered 1" [25mm] and the second screw centered 3/4" [19mm] from the edge of the Lateral Bracing Bracket. As shown in Fig. 36 - 38.
6. Position the Lateral Bracing Assembly into the desired installation position set a 45° angle. As shown in Fig. 39.
7. Using two Evolution Self-drilling Screws, fasten the Lateral Bracing Assembly onto the Post and Framing Member or Rafter. As shown in Fig. 40.

Note:

- 2" x 2" [51mm x 51mm] Purlin tubing is re-purposed as Lateral Bracing Support.
- **Minimum length recommended for Lateral Bracing Support: 24" [610mm].**

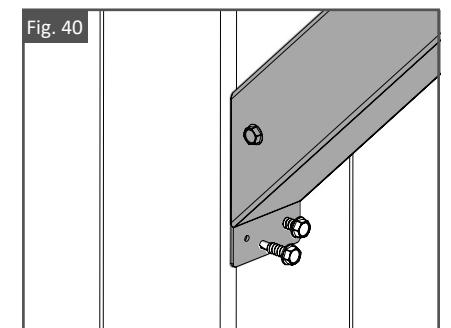
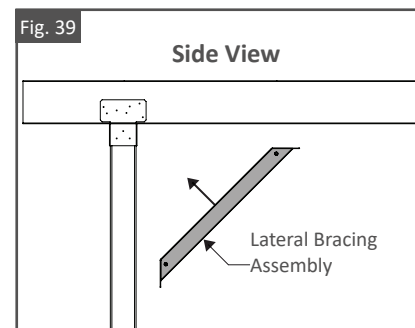
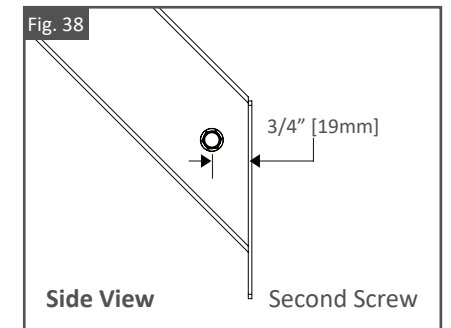
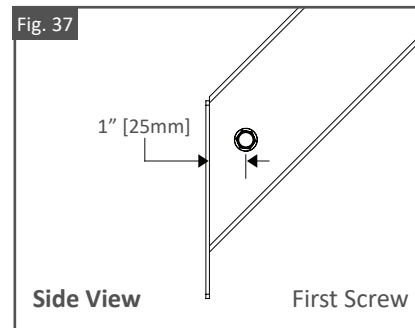
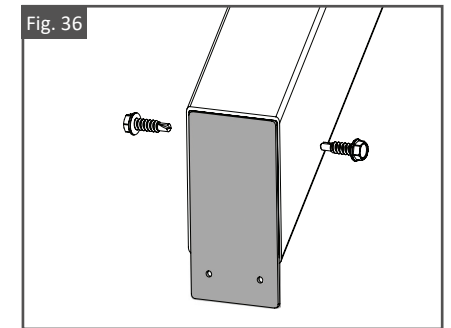
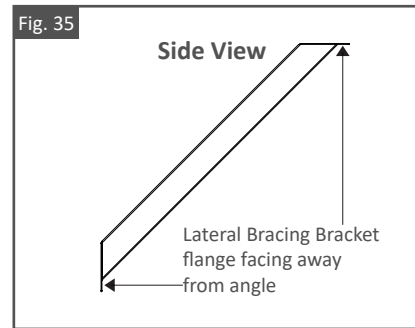
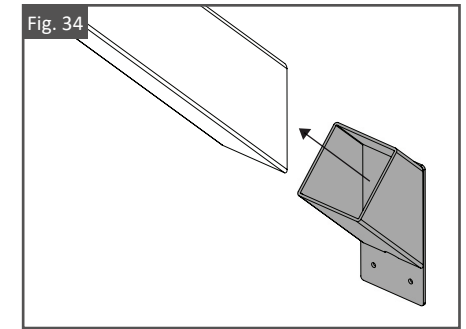
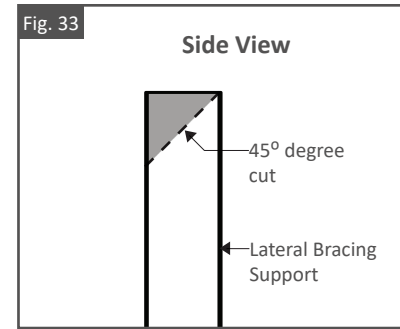

Connection 7: Rafter To Framing Member (F-50 Bracket)

1. Measure and mark desired on-center spacing onto top face of two opposite Framing Members.
2. Mount the F-50 Bracket centered along on-center spacing mark on inside face of the Framing Member. As shown in Fig. 41.
3. Use a Speed Square to position the F-50 Bracket perpendicular to the Framing Member.
4. Using Evolution Self-drilling Screws, fasten the F-50 Bracket onto the Framing Member. As shown in Fig. 42.
5. Mount the Rafter onto the F-50 Bracket and Framing Member. Be sure the top face of Rafter and Framing Member are flush. As shown in Fig. 43.
6. Using Evolution Self-drilling Screws, fasten the Rafter onto the F-50 Bracket. As shown in Fig. 43.
7. Alternatively, the F-50 Bracket can be flipped and installed with both faces of the bracket exposed and facing the away from the Rafter. As shown in Fig. 44.

Tip:

- Be sure all F-50 Brackets are orientated in the same direction.
- Be sure drainage holes on Rafters face down once installed. As shown in Fig. 45.

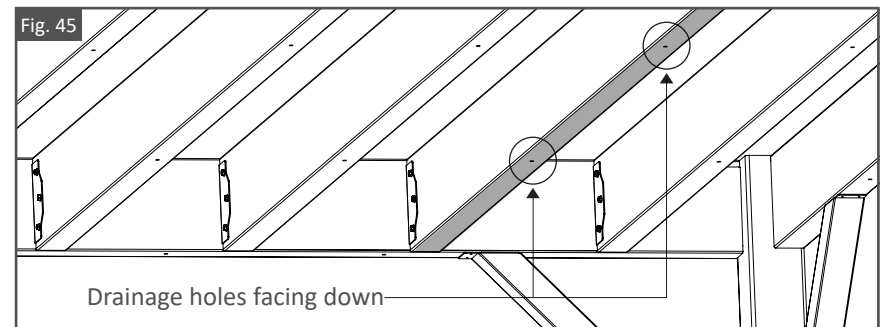
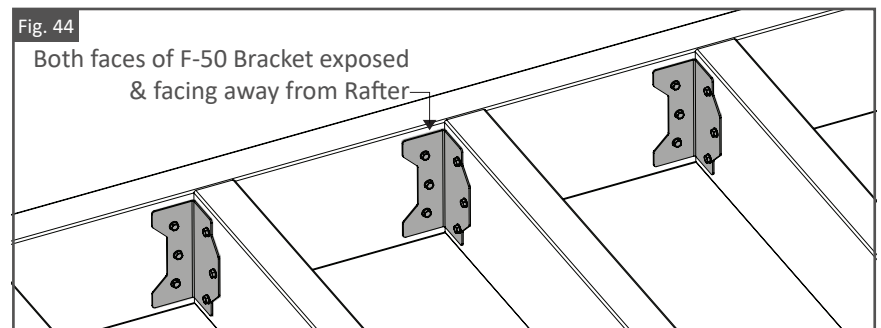
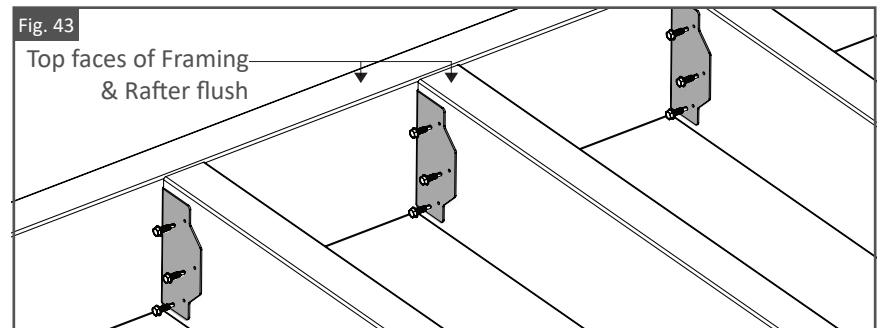
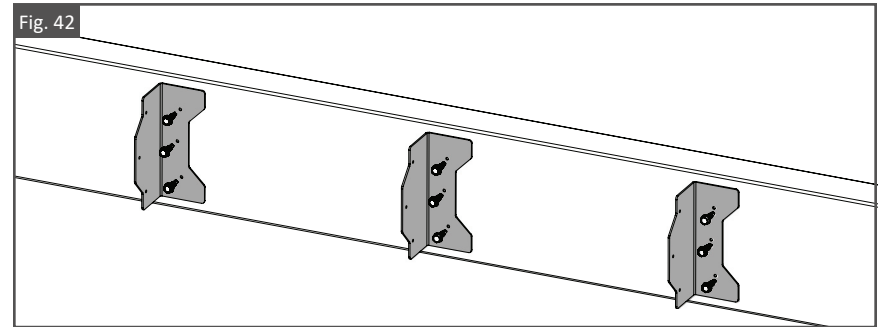
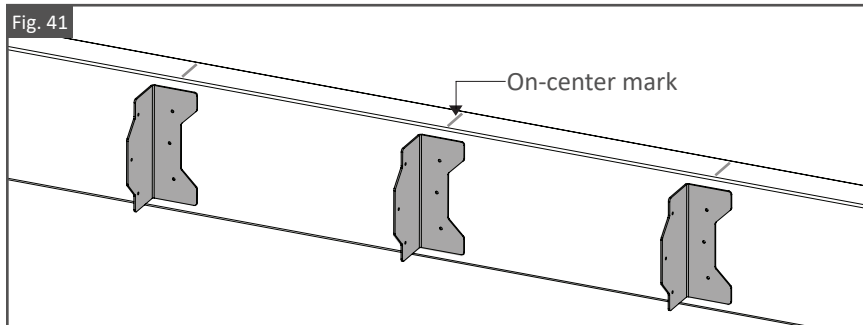

Connection 8: Rafter to Framing (Single or Double Hanger Bracket)

1. Measure and mark desired on-center spacing onto top face of two opposite Framing Members.
2. Mount the Single or Double Hanger Bracket onto the Framing Member and centered along on-center spacing mark. As shown in Fig. 46.
3. Using Evolution Self-drilling Screws, fasten the Single or Double Hanger Bracket onto the Framing Member. As shown in Fig. 47.
4. Insert the Rafter into the Single or Double Hanger Bracket. As shown in Fig. 48.
5. Using Evolution Self-drilling Screws, fasten the Single or Double Hanger Bracket onto the Rafter. As shown in Fig. 49.

Tip:

- Be sure drainage holes on Rafters face down once installed. As shown in Fig. 50.

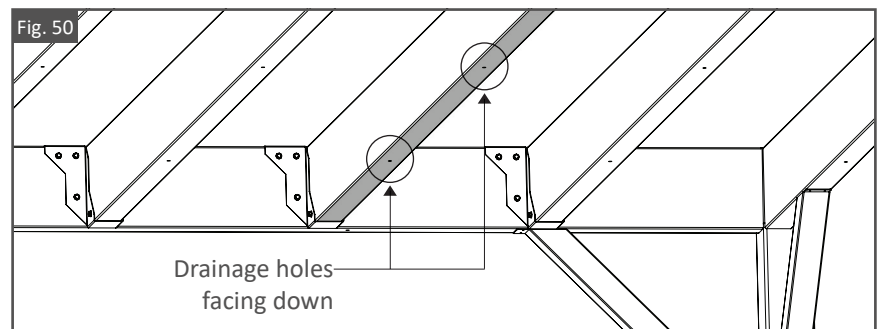
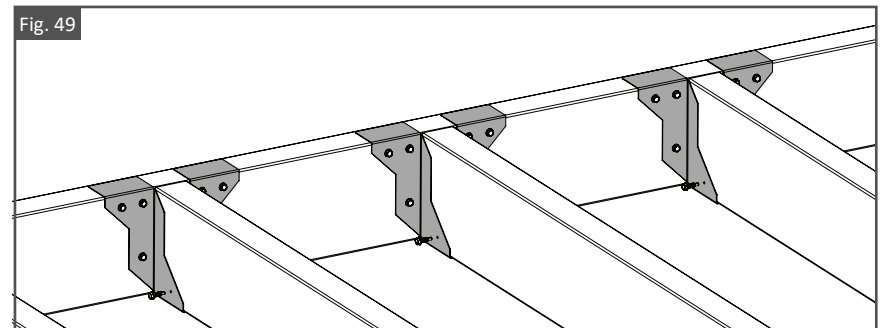
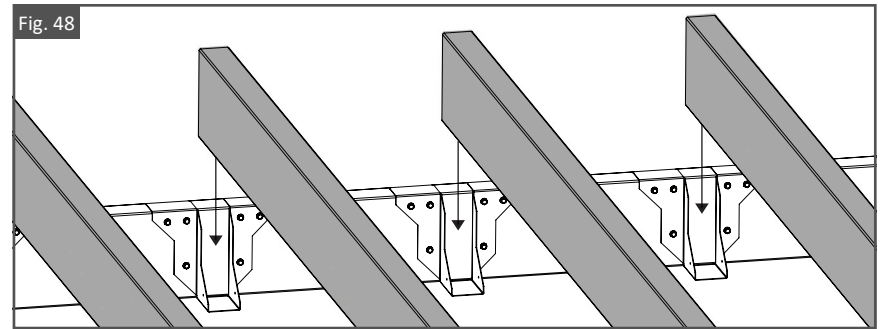
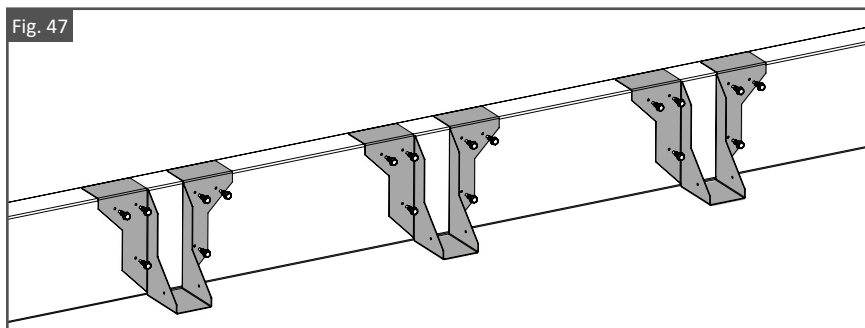
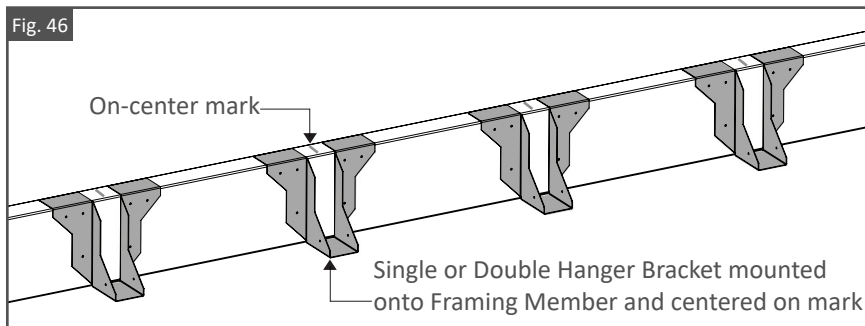

Connection 9: Rafter to Framing (Rafter Hanger Bracket)

1. Measure and mark centerline onto inside faces of two opposite Framing Members.
2. Measure and mark desired on-center spacing onto inside face of two opposite Framing Members. As shown in Fig. 51.
3. Using Evolution Self-drilling Screws, loosely fasten the center hole of each Rafter Hanger Bracket at each on-center marking and positioned along the centerline. As shown in Fig. 52.

4. Position each Rafter Hanger Bracket to desired angle. As shown in Fig. 53. 45° and 90° angles are marked by the slotted section in the back of each bracket.
5. Using Evolution Self-drilling Screws, fasten the remaining top and bottom holes of each Rafter Hanger Bracket and tighten the center screw. As shown in Fig. 54.
6. Insert the Rafter into the Rafter Hanger Brackets. As shown in Fig. 55.
7. Using Evolution Self-drilling Screws, fasten the Rafter Hanger Brackets onto the Rafter. As shown in Fig. 56.

Tip:

- Trim Framing Member/Rafter 3/8" [9.5mm] shorter than desired length to clear the screw heads of mounted Rafter Hanger Brackets.

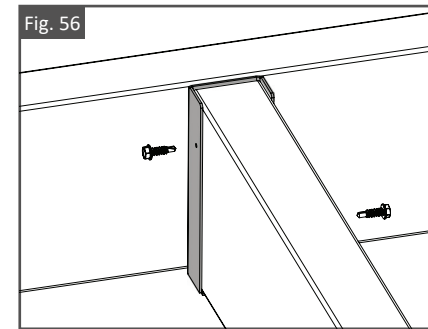
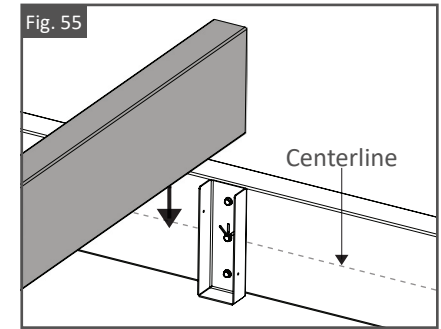
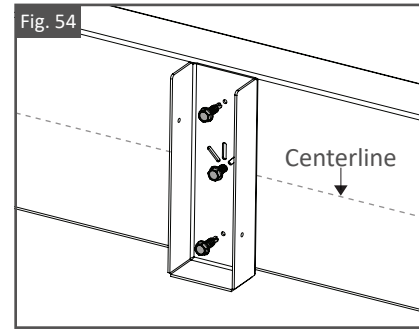
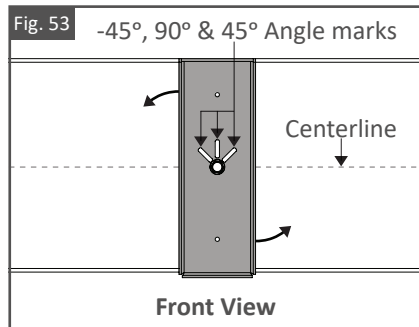
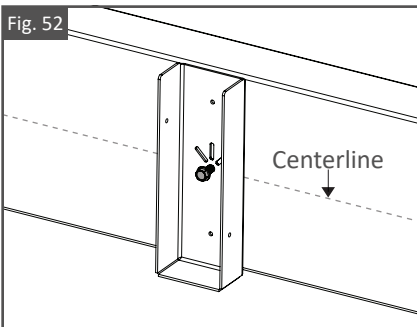
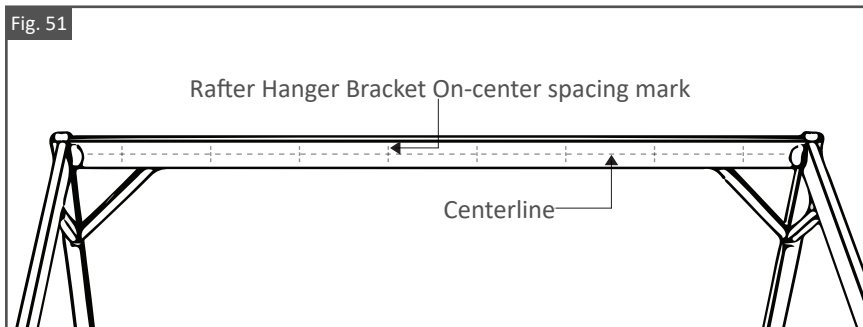

Connection 10: Single or Double Beam Joist To Rafter

1. Stagger two F-10 Brackets, one on each side of the Rafter. Fasten brackets using Evolution Self-drilling Screws. As shown in Fig. 57 & 58.

Tip:

- Be sure to have End Rafters on center with Posts. As shown in Fig. 59. This will allow for the Lateral Bracing Assembly to be centered on both Post and Joist when installed.

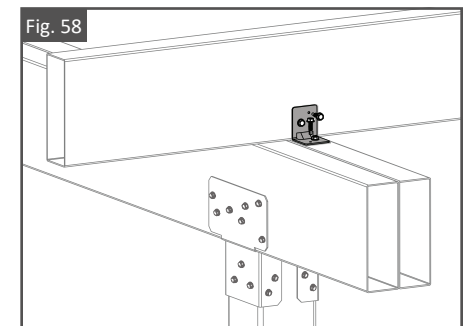
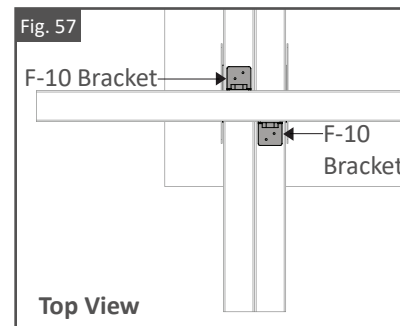

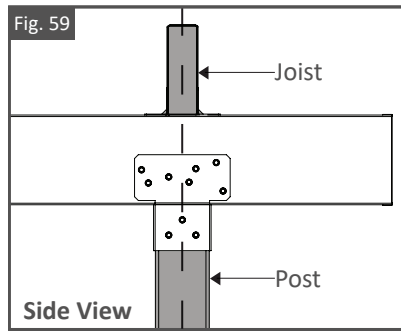

Connection 11: Rafter To Purlin

1. Using Evolution Self-drilling Screws, fasten one F-10 Bracket on each joist to Purlin connection. Be sure to position F-10 Brackets on same face of each connection. As shown in Fig. 60.

Tip:

- For each Purlin, at a minimum, F-10 Brackets should be mounted to each end rafter and the middle Rafter. As shown in Fig. 62.
- As a design alternative, Rafters can be rotated and installed horizontally. As shown in Fig. 61.

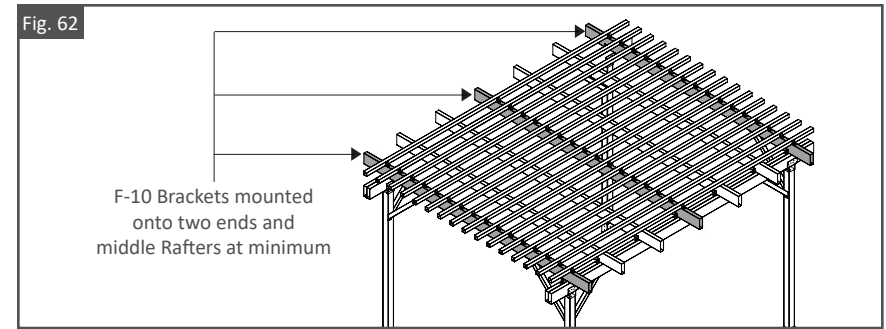
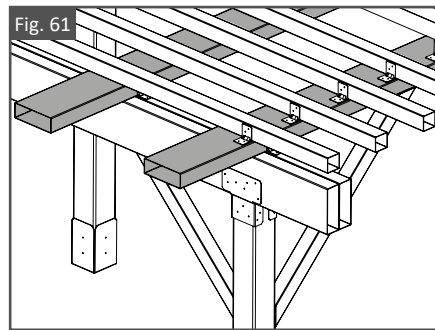
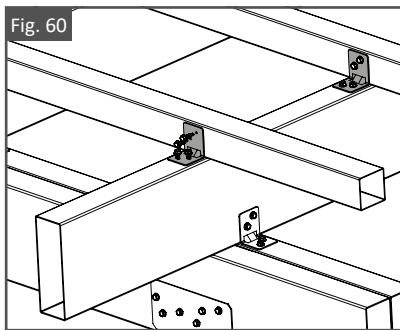

Connection 12: Rafter Tail to Post/ Rafter

Rafter Tail to Post:

1. Place the Rafter Tail insert in desired position on a Post. **Offset the Rafter Tail insert 1/16" [2mm]** from the top face of each Post. As shown in Fig. 63.
2. Using Evolution Self-drilling Screws, mount the Rafter Tail insert onto the Post. As shown in Fig. 64. Use a Speed Square to keep Rafter Tail insert plumb when fastening.
3. Slide Rafter Tail over the Rafter Tail insert. As shown in Fig. 65.
4. Using Evolution Self-drilling Screws, fasten the Rafter Tail onto the Rafter Tail insert through the guide hole on the top & bottom faces of the Rafter Tail. As shown in Fig. 66.

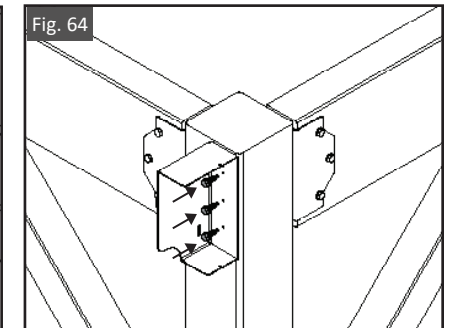
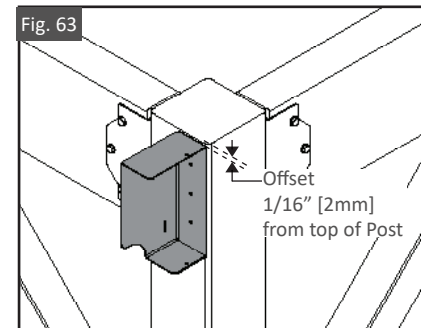

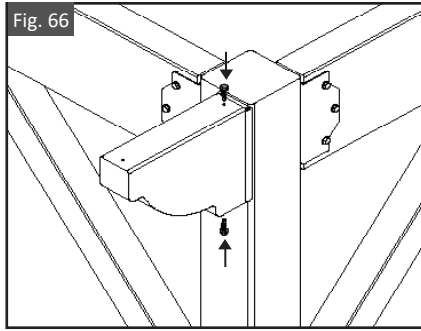
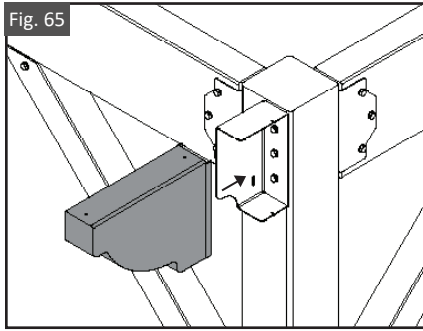

Rafter Tail to Rafter:

1. Slide the Rafter Tail insert into the exposed end of the Rafter up to the punched slot in the insert. The Rafter Tail insert should be recessed into the rafter a **minimum** of 1" [25mm]. As shown in Fig. 67.
2. Using an Evolution Self-drilling Screw, fasten into the Top face of the Rafter. As shown in Fig. 68. Be sure screw penetrates both Rafter and Rafter Tail insert.
3. Slide Rafter Tail over the Rafter Tail insert until the Rafter Tail flange lips sit over the evolution joist. As shown in Fig. 69. Use a Rubber Mallet to fully seat Rafter Tail.
4. Using Evolution Self-drilling Screws, fasten the Rafter Tail onto the Rafter Tail insert through the guide hole on the top & bottom faces of the Rafter Tail. As shown in Fig. 70.

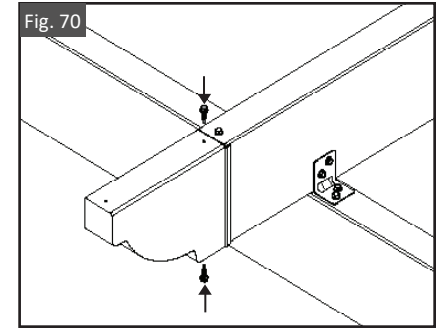
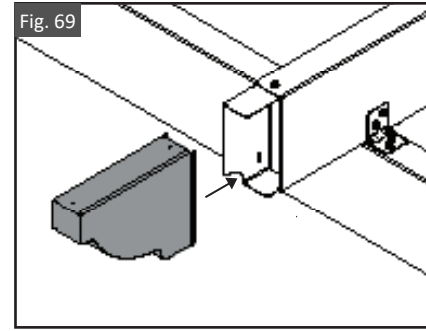
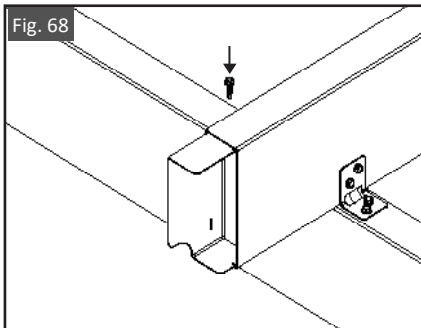
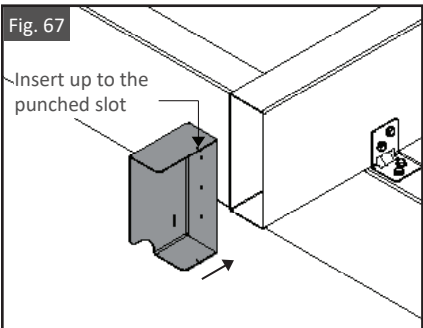

Connection 13: Joist/Framing Member Cap

1. Position the cap onto the exposed end of the Joist or Framing Member. As shown in Fig. 71.
2. Using Evolution Self-drilling Screws, fasten Joist/Framing Member Cap onto Joist. As shown in Fig. 72.

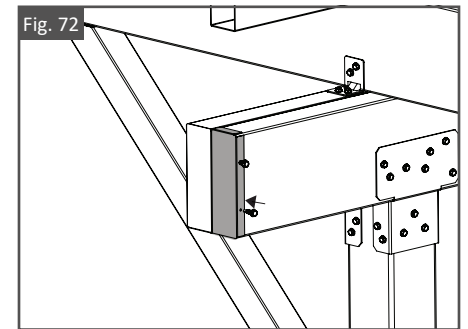
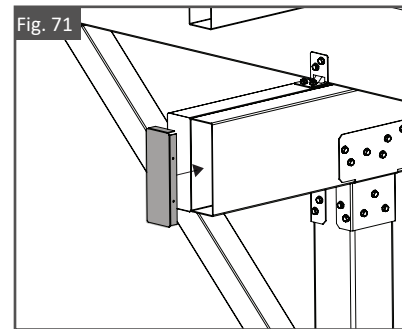

Connection 14: Purlin Cap

1. Position the Purlin Cap onto the exposed end of Purlin. As shown in Fig. 73 & 74. If required, use a Rubber Mallet to fully seat the Cap.
2. Using an Evolution Self-drilling Screw, fasten Cap onto the Purlin. As shown in Fig. 75 & 76. Position the screw 11/16" [18mm] from the end of the cap.

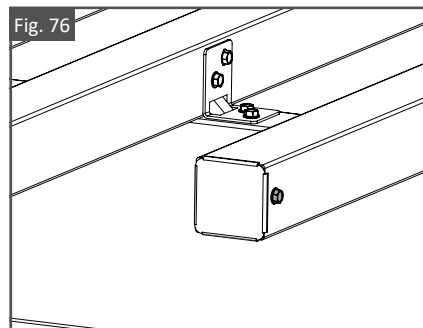
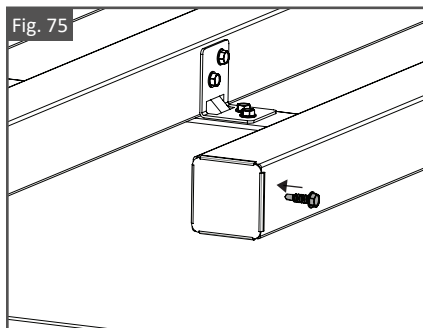
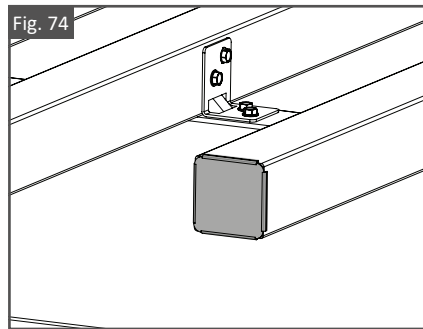
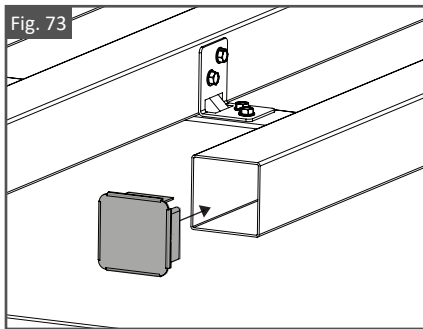

CARE & MAINTENANCE

Care And Maintenance Of Fortress Building Products Powder-Coated Products And Surfaces:

- Immediately after installation of your Fortress Building Products, clean powder-coated products and surfaces with a solution of warm water and non-abrasive, pH neutral detergent solution. Surfaces should be thoroughly rinsed after cleaning to remove all residues. All surfaces should be cleaned using a soft cloth or sponge.
- Ensure construction materials such as concrete, plaster, and paint splashes are removed immediately before they have a chance to dry. Failure to remove these materials may cause damage to the powder-coated surfaces.
- **DO NOT** allow metal shavings and/or chips to get dropped or blown into a pool, hot tub, or any other body of water. Staining could occur if this were to happen.
- The frequency of cleaning depends in part on the standard of appearance and also the requirements to remove deposits that may cause damage to the powder coating after prolonged exposure. Fortress recommends cleaning in three to four monthly intervals.
- **WARNING: Do not use strong solvents such as thinners, or solutions containing chlorinated hydrocarbons, esters, or ketones. Abrasive cleaners or cutting compounds should not be used.**

Cleaning Your Ultraspan Joist

What you will need



Soap



Water



Bucket



Sponge



Hard-Bristled
Broom



High Pressure Hose
With Fan Tip

STEP 1: Apply soapy water to your profile with a sponge.

STEP 2: Sweep the liquid over your profile using the hard-bristled broom, making sure to remove all dirt and residue from the gaps between the cladding boards. Sweeping in the direction of the grain is best.

STEP 3: If residue and/or dirt are still evident, a high pressure hose is very effective in removing stubborn and unavoidable organic waste.

***DO NOT** use standard composite cleaners on the UltraSpan Joist.

WARRANTY

To obtain and review a copy of the warranty, please go to:

<https://Fortressbp.com/warranties>. You can also contact:

(844) 909-1999 or write to: Fortress Building Products Warranty, 1720 N 1st St, Garland, TX 75040 to obtain a copy of the warranty.



JOIN THE REVOLUTION.

FortressBP.com | 866.323.4766

© 2023 Fortress Building Products.

Unless otherwise noted, all proprietary names are trademarks of Fortress Iron, LP. All rights reserved.

01/2023